

## Fiber Recovery Systems

### Applications

*This simple design permits a wide range of applications in the paper mill, pulp mill, or wood room for dewatering, filtering, thickening, and fiber classification. Minimal maintenance required, low cost operation, and fast ROI.*

### Features

- ▶ Single, duo, or triple screen designs
- ▶ FRP housing and 316 SIS slotted media
- ▶ Optional oscillating showers
- ▶ Wide variety of slotted media available

### Benefits

- ▶ Maximize recovery of expensive fiber
- ▶ High operating efficiency at a low cost/gpm
- ▶ Minimal maintenance and space requirement
- ▶ Initial stage of filtration for shower water

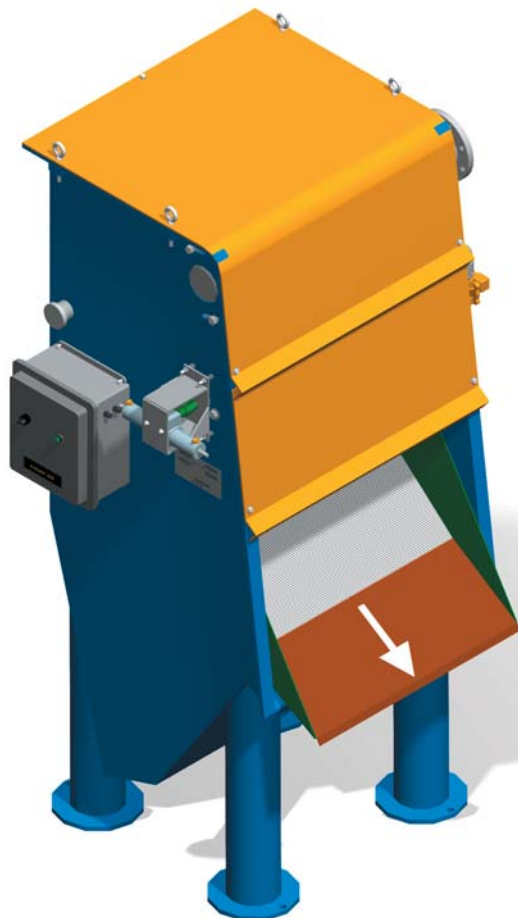

### Parabolic Screen Design

Patented\* parabolic screening surface provides a change in the angular momentum and varying slot opening for maximum capacity and highest operating efficiency. Thus, the slot opening is the smallest where the stock is most dilute and the change in angular momentum is greatest.

The Para-Flow is available with two or three different slot widths on the same screening surface—for dilute applications or when white water quality is a determining factor. Typically, the first 20% of the plate would have 0.007" slots, the next 20% would have 0.010" slots, and the remaining 60%, 0.020" slots. This minimizes slot width where the stock is most dilute and where it has the greatest change in angular momentum. Then, the 0.020" slots can be used to maximize capacity and thickening, even in dilute applications.

- ▶ Flow capacity up to 300 gpm (1,135 lpm) per screen.
- ▶ Non-clogging inlet nozzle—no inlet levers to push and no operator inspection required.
- ▶ Adjustable screening plate angle.
- ▶ The Para-Flow is available with optional, intermittent oscillating showers, complete with timers, oscillator, and solenoids. Normal operation is for 15 seconds on at a time, once every three minutes. Clarified or clean white water is required.

# PARA-FLOW PARABOLIC SCREENS

Model		A	B	C	D	E	F	G	H	I	J	Shower (Average*)	Weight (lbs/kgs)	
		in.	mm										Shipping	Operating
PF1	in. mm	92.5 2350	48.0 1220	45.5 1155	67.25 1708	25.25 641	18.0 457	12.0 305	5.0 127	8.0 203	10.0 254	1.1 gpm 4 lpm	400 182	1500 686
PF2	in. mm	92.5 2350	74.0 1880	45.5 1155	67.25 1708	25.25 641	34.75 883	14.5 368	6.0 152	12.0 305	10.0 254	2.2 gpm 8 lpm	800 364	3000 1370
PF3	in. mm	92.5 2350	107.0 2718	45.5 1155	67.25 1708	25.25 641	51.5 1318	15.5 394	6.0 152	14.0 355	10.0 254	3.3 gpm 12 lpm	1200 546	4500 2057

\* Shower (Average) is water usage at 15 seconds every three minutes at 60 psig.

Single Slot Openings	.007"	.010"	.015"	.020"	.030"	.040"	.060"	Special Order
Two-Slot Openings	25% .007" and 75% .010"				25% .010" and 75% .020"			Special Order
Three-Slot Openings	20% .007" and 20% .010" and 60% .020" (Dilute Applications)							
	20% .010" and 20% .020" and 60% .040" (Rough Applications)							

General Dimensions — Not certified for construction or installation.

Contact your Kadant AES Sales or Filtration Application Engineer for specific recommendations

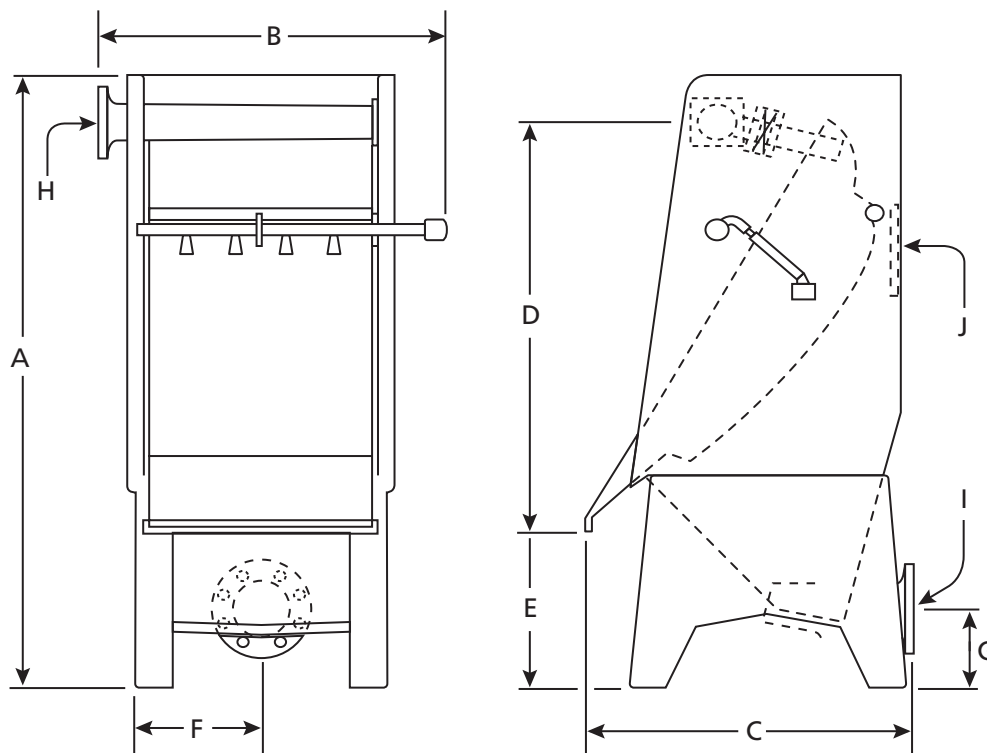

## Options

- ▶ Widths: 33", 66", or 99"  
(838, 1676, or 2515 mm)
- ▶ Intermittent oscillating showers
- ▶ Duo-Slot (two slot sizes per plate)
- ▶ Tri-Slot (three slot sizes per plate)
- ▶ Front and/or top covers

**KADANT**  
AN ACCENT ON INNOVATION

Kadant is a leading global supplier of products and services that improve productivity and quality in paper production and other process industries. For the nearest location and contact, visit our Website.

[www.kadant.com](http://www.kadant.com)

Contact us:

KADANT AES DIVISION  
436 Quaker Road  
Queensbury, NY 12804 USA

Tel: +1-518-793-8801  
Fax: +1-518-793-9392

Para-Flow-1000 03/2009  
© 2009 Kadant Inc.