

Trim Squirt Technology

Applications

Clean and precise sheet trimming is essential to operate a high-efficiency paper machine. The VersaTrim System provides an accurate and adjustable trim squirt system for the wet-end of the paper machine.

Features

- ▶ Easy to adjust MD nozzle angle
- ▶ Precise CD adjustment
- ▶ Quick, safe replacement
- ▶ Minimizes contaminant build-up and spray back

Benefits

- ▶ Fewer wet-end breaks due to drop-offs
- ▶ Improved sheet edge
- ▶ Reduced fiber mist equals less wash-ups
- ▶ More consistent turn-ups at the reel

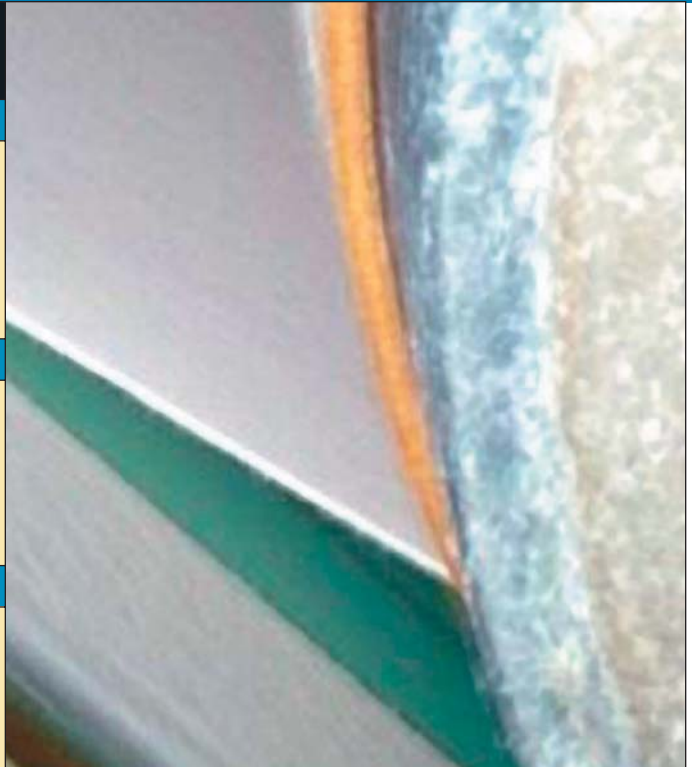

Kadant's VersaTrim turnkey solution maximizes paper machine efficiency and minimizes wet-end breaks due to drop-offs and poor edge trim quality.

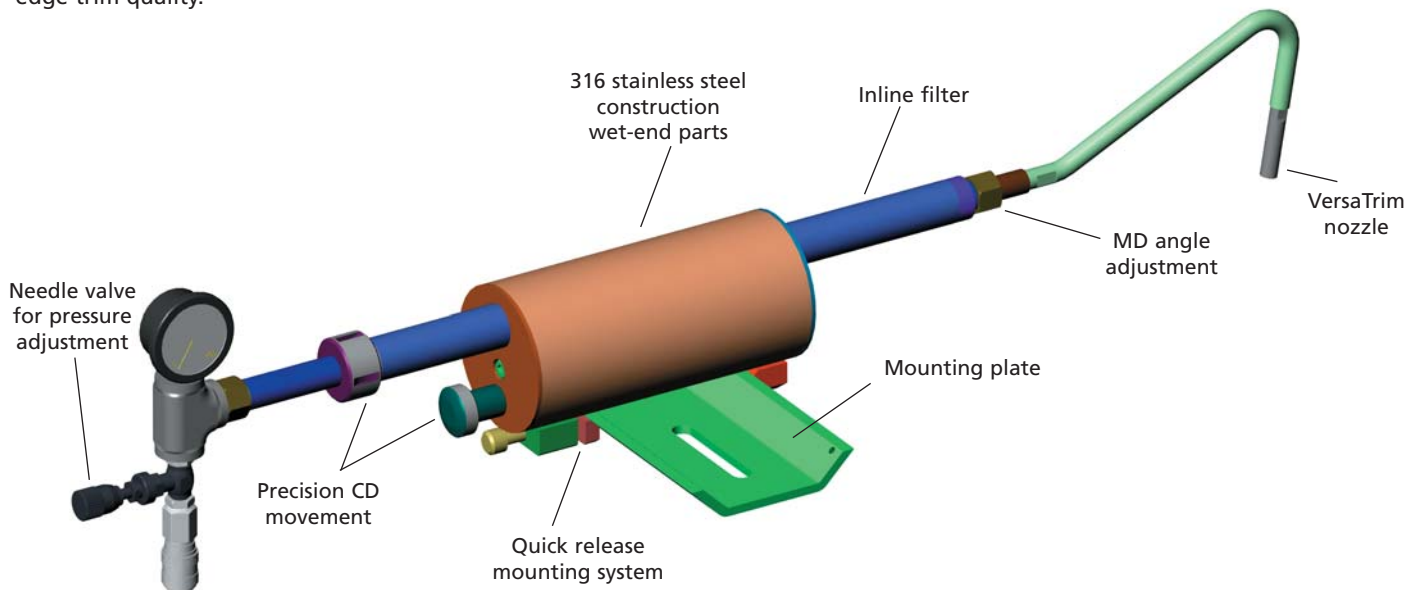

Trim Squirt Nozzles

Accurate, precise trim edge

Tips can be provided in ruby, sapphire, duracerm, or stainless steel.

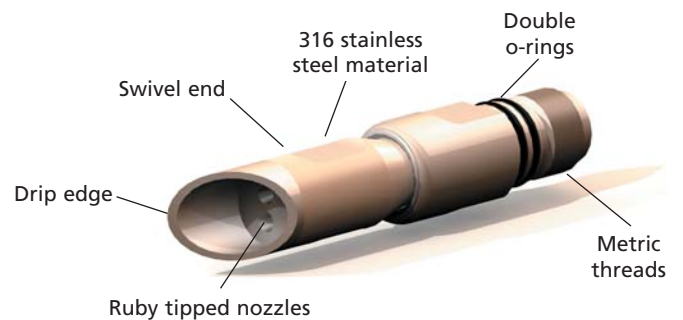

VERSATRIM SYSTEM

Trim Nozzle Operating Recommendations

Basis Weight				(PSI/BARS)												
#/1000	#/3000	#/3300	gr/M2	305	457	610	762	914	1067	1219	1372	1524	1676	1829	1981	M/minute
				1000	1500	2000	2500	3000	3500	4000	4500	5000	5500	6000	6500	FPM
10.0	30	33	48.8	132/9.1	198/13.6	148/10.2	185/12.7	222/15.3	259/17.8	296/20.4	333/22.9	370/25.5	407/28.0	444/30.6	514/35.4	
13.3	40	44	65.1	135/9.3	222/15.3	165/11.4	207/14.2	248/17.1	289/19.9	331/22.8	372/25.7	414/28.5	455/31.4	468/32.3	507/35.0	
16.7	50	55	81.4	147/10.1	242/16.7	180/12.4	225/15.5	271/18.6	316/21.8	361/24.9	406/28.0	451/31.1	468/32.3	511/35.2	553/38.1	
20.0	60	66	97.6	146/10.1	237/16.3	194/13.3	242/16.7	291/20.0	339/23.4	388/26.7	436/30.1	485/33.4	503/34.6	548/37.8		
23.3	70	77	113.9	155/10.7	252/17.4	206/14.2	257/17.7	309/21.3	360/24.8	412/28.4	463/31.9	485/33.4	534/36.8	582/40.1		
26.7	80	88	130.2	153/10.5	123/8.48	194/13.3	242/16.7	291/20.0	339/23.4	388/26.7	436/30.1					
30.0	90	99	146.4	160/11.0	128/8.88	203/14.0	254/17.5	304/21.0	355/24.5	406/28.0	457/31.5					
33.3	100	110	162.7	167/11.5	134/9.25	211/14.6	264/18.2	317/21.9	370/25.5	423/29.2	476/32.8					
36.7	110	121	179.0	163/11.2	130/8.98	200/13.8	250/17.2	301/20.7	351/24.2							
40.0	120	132	195.2	169/11.6	134/9.29	207/14.3	259/17.8	311/21.4	363/25.0							
43.3	130	143	211.5	174/12.0	139/9.59	214/14.7	267/18.4	321/22.1	374/25.8							

Trim Nozzle Orifice	
mm	Inch
0.35	0.014
0.4	0.016
0.45	0.018
0.5	0.020
0.6	0.024
0.7	0.028
0.8	0.031
0.9	0.035

Single Orifice Dual Orifice →

Turnkey System

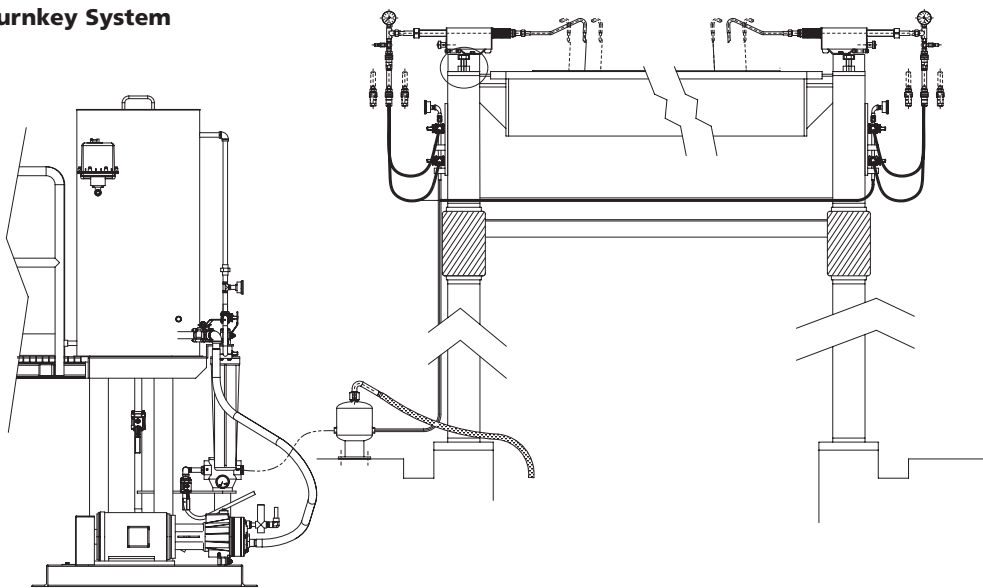

VersaTrim Pump Skid



- ▶ Featuring a Unigy™ High Efficiency Pump System
- ▶ 600 psi capability
- ▶ Temperature controlled water delivery
- ▶ Self-contained
- ▶ Low-energy usage
- ▶ 10 micron duo water filtration
- ▶ Redundant spare pump
- ▶ Precision pressure control (no pulsation)

KADANT
AN ACCENT ON INNOVATION

Kadant is a leading global supplier of products and services that improve productivity and quality in paper production and other process industries. For the nearest location and contact, visit our Website.

www.kadant.com

Contact us:

KADANT AES
436 Quaker Road
Queensbury, NY 12804 USA

Tel: +1-518-793-8801
Fax: +1-518-793-9392