

## Disassembly and Bench Repair of Type PTX End Cap

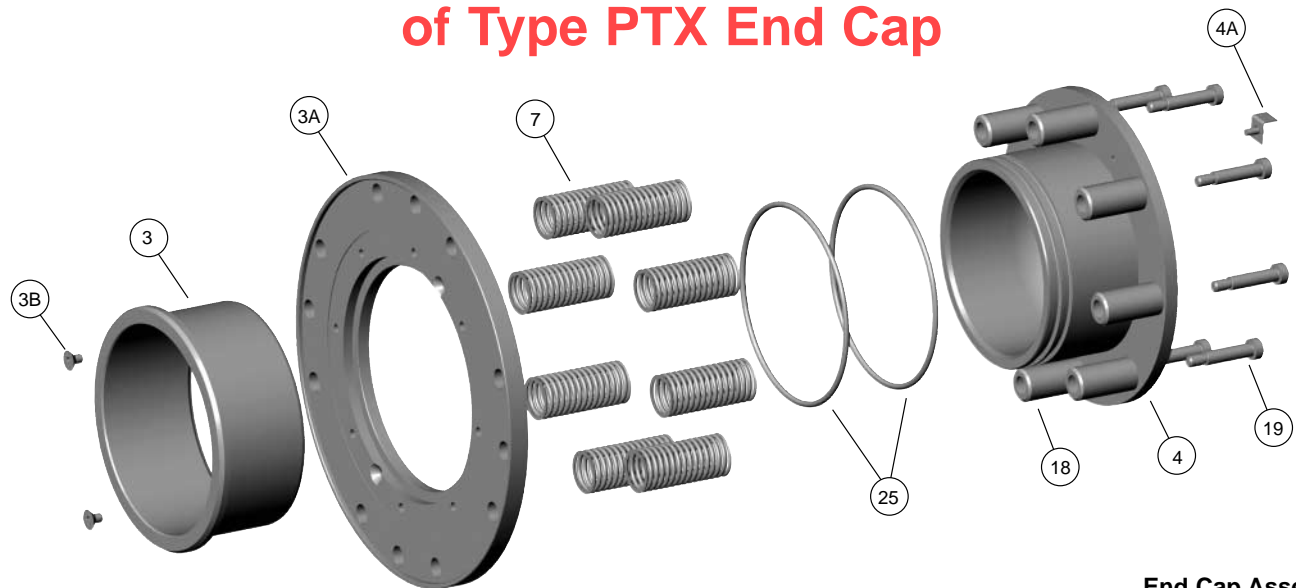

End Cap Assembly

### SPARE PARTS:

Item #	Qty	Description
7	8	Springs (9800)
7	6	Springs (9750)
25	2	O-rings or (1) Lip Seal
19	8	Shoulder Screws (9800)
19	6	Shoulder Screws (9750)
*	1	O-Ring Lube

**NOTE:** Do not use anti-seize or petroleum-based products on o-rings. Only lubricate the o-rings with the silicone lubricant supplied with the Kadant Johnson repair kit.

Please follow your company's safety procedures whenever working on Kadant Johnson rotary joints and read all of the instructions completely before proceeding.

Please refer to the assembly drawings supplied with your Kadant Johnson rotary joint for part identification. If you have any questions, please contact your Kadant Johnson Representative or Kadant Johnson.

### DISASSEMBLY:

#### STEP 1.

Place end cap assembly in a press with the flat seal ring surface facing up. See Figure 1. Protect the seal ring surface using a piece of wood and push down on nipple (4) slightly compressing the springs (7).

#### STEP 2.

Using a socket head allen wrench, loosen, remove, and discard shoulder screws (19).

#### STEP 3.

Slowly release the press and the nipple (4) will move out of the end cap (3). Lift the nipple off the springs (7) and discard the springs.

### CLEANING AND INSPECTION:

#### STEP 4.

Using a Scotch Brite pad and solvent, clean and inspect the end cap (3) bore. It is an o-ring surface and should be smooth, not scored or pitted. Replace (if required) by removing two flat head screws (3B). Tap the end cap on a piece of wood to release it from the end flange (3A). Discard end cap and save the end flange for reuse.

#### STEP 5.

Remove the o-rings or lip seal (25) from the nipple (4) and discard. Clean the entire nipple, o-ring grooves, flat sealing surface, and the nipple end where it fits into the end cap bore. Inspect the o-ring/lip seal groove for steam cutting or damage. Inspect the surface of the nipple where it rides in the end cap, it should be smooth, not worn or scored. Inspect the flat sealing surface of the nipple, it should be smooth, not scored or steam cut. If any part of the nipple is damaged, the nipple should be replaced. Inspect seal wear tab (4A), replace if damaged or worn.

#### STEP 6.

Inspect the torque tubes (18) on the nipple. Make sure they are not worn where the head of the shoulder bolt rests inside. If a step is present or the tube is worn, the nipple should be replaced. Field replacement of the torque tubes can be done, but is not recommended. If field replacement is attempted, do so by heating the area of the flange around the torque tube. Do not damage the flat seal ring surface while heating the flange. Using a pipe wrench, back out the torque tube. Let the nipple cool and then clean the threaded holes in the nipple flange with acetone. Place a small amount of Locktite 272 on the shouldered end of the new torque tube, install and tighten to 200 ft-lbs.

### REASSEMBLY:

#### STEP 7.

If the end cap (3) was removed from the end flange (3A), place the end cap through the end flange and secure into position

using two flat head screws. Tighten securely. Place the end cap in a press resting on the end flange.

**STEP 8.**

Lubricate two new o-rings and place them into the o-ring grooves in the nipple. If using a single lip seal, lubricate the new lip seal and place into the groove in the nipple with the sealing lip pointed away from the flat sealing surface of the nipple. Please see Figure 1 for proper lip seal orientation.

**STEP 9.**

Place the appropriate amount of new springs into the spring bores in the end flange (3A). Position the nipple (4) over the end cap/springs. While aligning the springs with the torque tubes, align the nipple with the end cap (3) bore. Place the block of wood onto the flat sealing face on the nipple (4) and push it down into the end cap assembly. If a lip seal is used, make sure the lip is not folded as it slides into the end cap bore. The lip seal can also be viewed from the end flange side after assembly is completed. If the lip seal is damaged, a new one should be installed.

**STEP 10.**

Place a small amount of Locktite 272 on each shoulder screw (19). Pass the shoulder bolt through the torque tube and tighten into position using 40 ft-lbs of torque. Once all the screws are tightened, the press can be released.

The end cap assembly is now ready for service. Please follow the Kadant Johnson rotary joint installation instructions.

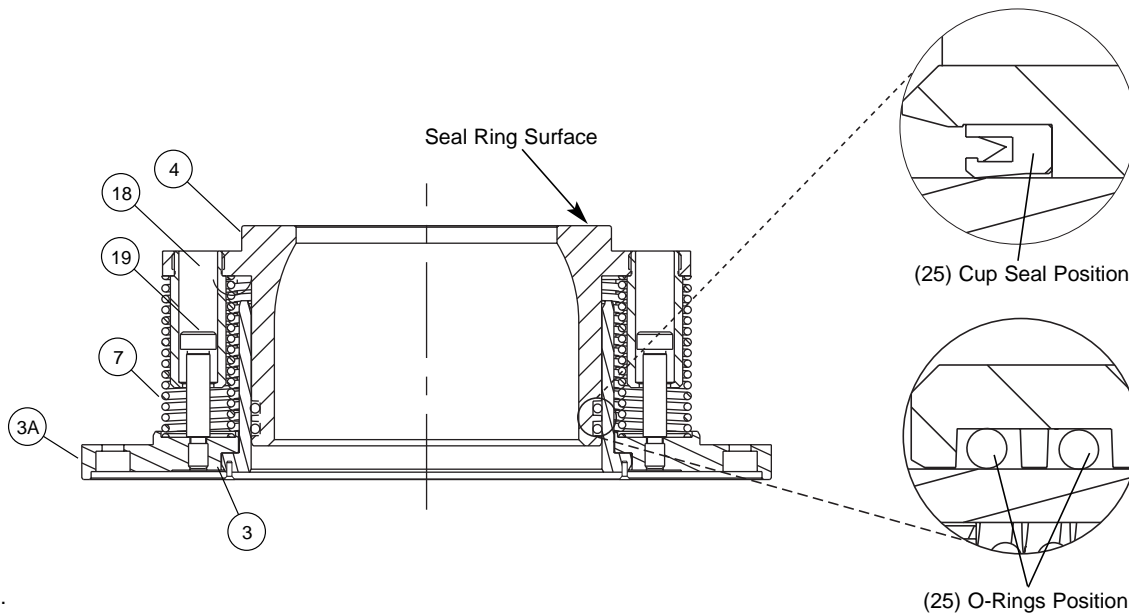

Figure 1.

The Kadant Johnson Warranty

Kadant Johnson products are built to a high standard of quality. Performance is what you desire: that is what we provide. Kadant Johnson products are warranted against defects in materials and workmanship for a period of one year after date of shipment. It is expressly understood and agreed that the limit of Kadant Johnson's liability shall, at Kadant Johnson's sole option, be the repair or resupply of a like quantity of non-defective product.



[www.kadantjohnson.com](http://www.kadantjohnson.com)