

Disassembly and Repair of Type ELSJ Joint With ISSS Stationary Syphon

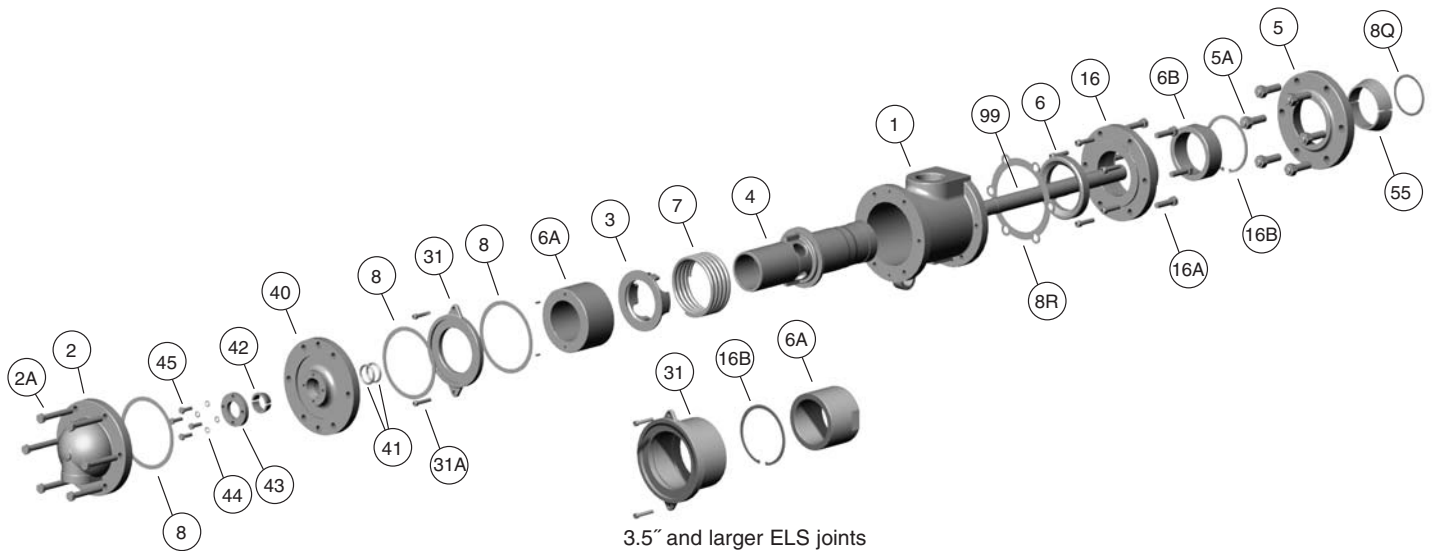

3.5" and larger ELS joints

Please follow your company's safety procedures whenever working on Kadant Johnson rotary joints. Read all of the instructions completely before proceeding.

Please refer to the assembly drawings supplied with your Kadant Johnson rotary joint for part identification. If you have further questions, please contact your representative or Kadant Johnson.

Tighten all fasteners in a star pattern. See joint assembly drawing for torque specifications.

NOTE: Do not use anti-seize or petroleum-based products on o-rings. Only lubricate the o-rings with the silicone lubricant supplied with the Kadant Johnson repair kit. Prior to handling lubricants, consult MSDS information.

REMOVAL:

STEP 1

Disconnect flex hoses from rotary joint.

STEP 2

Loosen and remove head bolts (2A) Remove head (2). Remove gasket (8) and clean gasket surfaces.

STEP 3

Mark the end of the horizontal pipe (99) where it passes through the pressure plate (43) or measure and record the distance from the pressure plate to the end of the horizontal pipe. See Figure 1. Mark the top center of the horizontal pipe. The horizontal pipe must be reinstalled in its original position, so horizontal pipe/syphon clearances inside the dryer will be maintained.

STEP 4

Remove pressure plate retaining bolts and lockwashers (44 & 45) and remove pressure plate (43).

STEP 5

Remove split wedges (55) by pulling out on the horizontal pipe (99). In some cases a horizontal pipe handling tool will need to be inserted into the center of the horizontal pipe. See drawing B5733 for 1" pipe and B5734 for 1 1/4" pipe. Insert the tool and tighten the nut on the all-thread rod. Once installed, the pipe can be moved as required. If necessary, the "U" bracket can be installed over the all-thread rod and used as a puller if the split wedges are stuck.

STEP 6

Remove anti-rotation device.

STEP 7

Remove Q flange retaining nuts (5A) and slide the Q flange (5) away from the journal. Remove the rotary joint. Remove the Q flange and split wedges (55) from the nipple (4). Set the Q flange and split wedges aside for reuse. If the rotary joint is threaded to the roll, loosen the nipple at the journal flange.

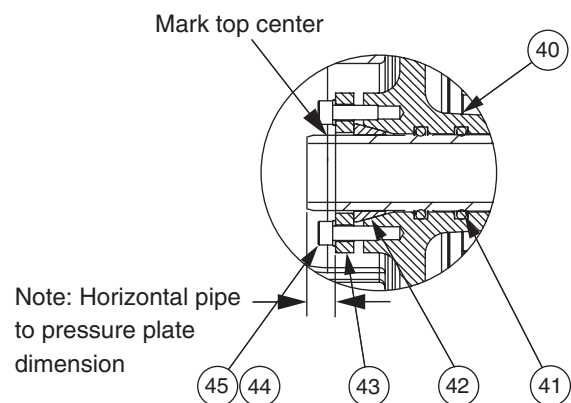

Figure 1

STEP 8

Position the rotary joint through a hole in a suitable work surface with the nipple (4) passing through the hole first so the joint will rest on the wear plate (16).

STEP 9

During this step, prepare to contain the spring force that is present within the joint. Remove the wedge plate (40) along with the assembly plate (31) by removing two screws (31A).

STEP 10

Remove the following: internal guide (6A), spring shoulder (3), spring (7), nipple (4), and seal ring (6).

NOTE: ELS joints that are 3.5" and larger, the internal guide (6A) is contained in the assembly plate (31) and is removed with it.

STEP 11

Inspect the following items for scoring or excessive wear and replace as required: nipple (4), seal ring (6), external guide (6B), and wear plate (16). To replace the wear plate, remove wear plate bolts (16A) and separate wear plate from body (1). Clean gasket surface on the body and install a new wear plate gasket (8R). Place wear plate on body and secure into position with wear plate bolts (16A). Replace external guide (6B). Install snap ring (16B) to hold the external guide in position.

NOTE: ELS joints that are 3.5" and larger, replace the internal guide (6A) by removing the retaining ring (16B) and sliding it out of the assembly plate (31). Install a new guide, making sure the slot in the guide engages the woodruff key in the assembly plate. Secure into position with the retaining ring.

STEP 12

Remove the o-rings (41) from the wedge plate (40). Clean and inspect o-ring grooves for steam cutting. Replace wedge plate if damaged. Lubricate two new o-rings (41) with silicone o-ring lubricant and install into wedge plate o-ring grooves.

STEP 13

Place parts back into the joint body in the following order; seal ring (6) with the flat face against the wear plate, nipple (4), spring (7), spring shoulder (3), and internal guide (6A) with the pin holes facing out.

NOTE: ELS joint that are 3.5" and larger, install the internal guide and assembly plate using a new gasket (8) during this step. There are no pin or pin holes to align.

STEP 14

Place a new gasket (8) between the body (1) and the assembly plate (31). Place a new gasket (8) between the wedge plate (40) and the assembly plate (31). Compress the spring using the wedge plate and assembly plate making sure the pins in the assembly plate are aligned with the pin holes in the internal guide. Make sure the keyway in the spring shoulder is aligned

with the key on the nipple. Once in position secure wedge plate/assembly plate using socket head cap screws (31A). Tighten cap screws evenly to 10 ft-lbs.

STEP 15

Place a new copper gasket (8Q) into the recess in the journal flange. Make sure the end of the horizontal pipe (99) is smooth and clean where it engages the o-rings (41) in the wedge plate (40). Install the rotary joint assembly back onto the roll by passing it over the horizontal pipe (99), making sure the horizontal pipe passes through the o-rings (41) in the wedge plate (40). Secure the joint into position using the Q flange (5) and split wedges (55) or thread the nipple (4) back into the roll and tighten. Tighten the Q flange evenly using a star pattern while making sure the gap between it and the journal flange is even. The gap should be approximately 1/8" (3 mm) around the circumference of the flange. The Q flange should not tighten against the journal flange surface.

STEP 16

Place split rings (42) into the recess in the wedge plate (40). Place pressure plate (43) over the split rings and loosely install the screws and lockwashers that secure pressure plate (44 and 45).

STEP 17

Position syphon as it was in Step 3. Tighten pressure plate screws evenly to 10 ft-lbs.

STEP 18

Clean the gasket surface on the head (2). Place a new gasket (8) and position head onto the body (1). Secure into position using head bolts (2A).

STEP 19

Install anti-rotation device.

STEP 20

Connect steam and condensate hoses. Turn valves back on and the joint is ready for service.

Dimensions are for reference only and subject to change. Certified drawings are available on request. Please refer to Kadant Johnson Drawing Number A37640 for torque specifications.

The Kadant Johnson Warranty

Kadant Johnson products are built to a high standard of quality. Performance is what you desire: that is what we provide. Kadant Johnson products are warranted against defects in materials and workmanship for a period of one year after date of shipment. It is expressly understood and agreed that the limit of Kadant Johnson's liability shall, at Kadant Johnson's sole option, be the repair or resupply of a like quantity of non-defective product.

KADANT
AN ACCENT ON INNOVATION
www.kadant.com