

# Disassembly and Repair of Type PTX Joint with Cantilever Syphon

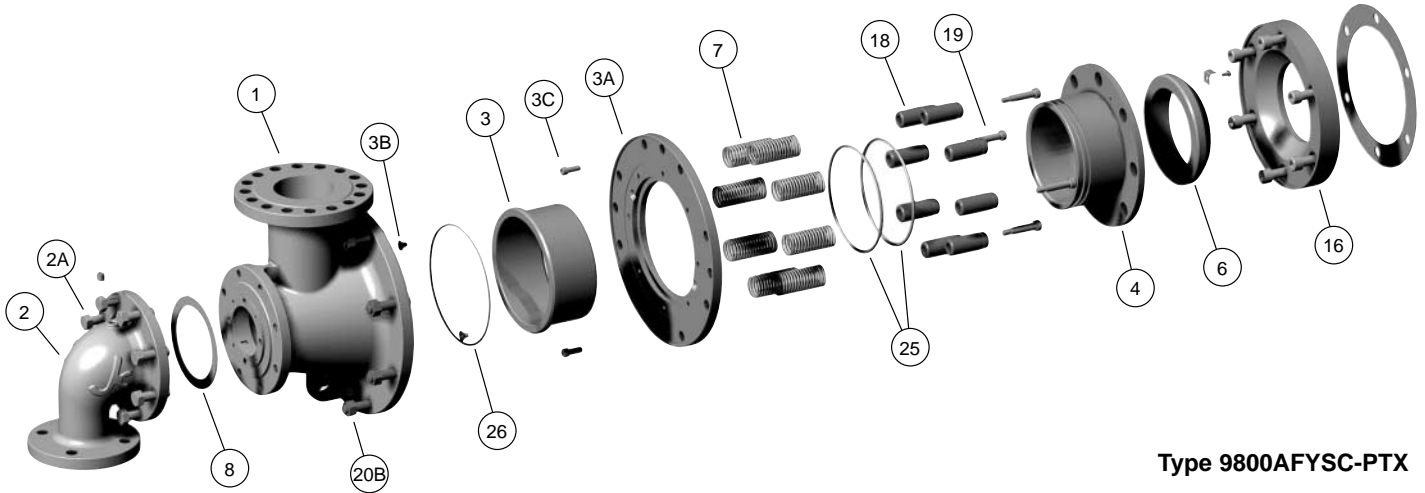

Type 9800AFYSC-PTX

## REPAIR KITS ARE AVAILABLE CONSISTING OF:

Item #	Qty	Description
6	1	Carbon Seal
8	1	Gasket
25	2	O-Rings or (1) Cup Seal
26	1	O-Ring
--	1	O-Ring Lube

**NOTE:** Please follow your company's safety procedures whenever working on Kadant Johnson rotary joints and read all of the instructions completely before proceeding.

In some cases the cup seal (25) will have two o-rings substituted in that position. Please review the assembly drawing supplied with the Kadant Johnson rotary joint. If you have any questions, please contact your Representative or Kadant Johnson.

## REMOVAL AND DISASSEMBLY:

### STEP 1.

Release residual pressure in the system. Close the inlet and outlet valve. Allow the joint to cool sufficiently and then disconnect the inlet and outlet piping from the joint.

### STEP 2.

Remove head bolts (2A) and head (2).

### STEP 3.

Bend the locking ring tabs back that secure the large hollow bolt (1C) holding the cantilever syphon tube into the joint body (1). Loosen the hollow bolt approximately 1/4". Install the syphon removal plate with eight bolts (2A) over the hollow bolt. Tighten the bolts evenly until the cantilever syphon tube breaks free of the locking taper. Giving the syphon removal plate a sharp rap with a lead hammer will aide in loosening the cantilever syphon tube. Once the cantilever syphon tube is loose, remove the syphon removal plate, hollow nut, and lockwasher. If equipped, discard the o-ring that is inside the hollow bolt.

### STEP 4.

Remove the hex nuts (20B). Prepare to support the weight of the joint body and remove it. Leave the cantilever support tube positioned where it is after the body is removed. Discard the o-ring (26) between the body and the end cap (3).

Note: If the cantilever support tube needs to be moved for bearing or gear work, it can be accomplished by rotating it 180 degrees so the syphon will clear the dryer bars and then pushing it into the dryer journal.

## SERVICING THE JOINT:

### STEP 5.

Remove four socket head cap screws (3C) that secure the end flange (3A) to the ring bracket (20). As the socket head cap screws are loosened, the end flange will move away from the ring bracket. When removing the end flange assembly (3, 3B, & 3C), prepare to capture the seal ring by wrapping a rag around the support tube. This will prevent damage to the seal ring as it falls free of the wear plate (16).

### STEP 6.

Inspect the wearing surfaces of the wear plate for scratches and wear. Replace if necessary.

### STEP 7.

Protect the flat face of the nipple and the o-ring surface of the end cap from damage while performing this operation by placing a piece of wood underneath the end flange and on top of the nipple before compressing it. Remove the nipple (4) from the end cap assembly (3, 3B, & 3C) by placing the assembly in a press with the nipple wear surface (flat face) facing up. Compress the nipple about 1/4" and remove shoulder screws (19). Release the press and the nipple will slide out of the end cap.

### STEP 8.

Remove the o-rings or cup seal (25) and discard. Inspect the nipple sealing surface for damage or wear. Using solvent and mild abrasive such as Scotch Brite, clean the o-ring or cup seal groove and their adjacent sealing surfaces. If pitted or steam cut, replace.

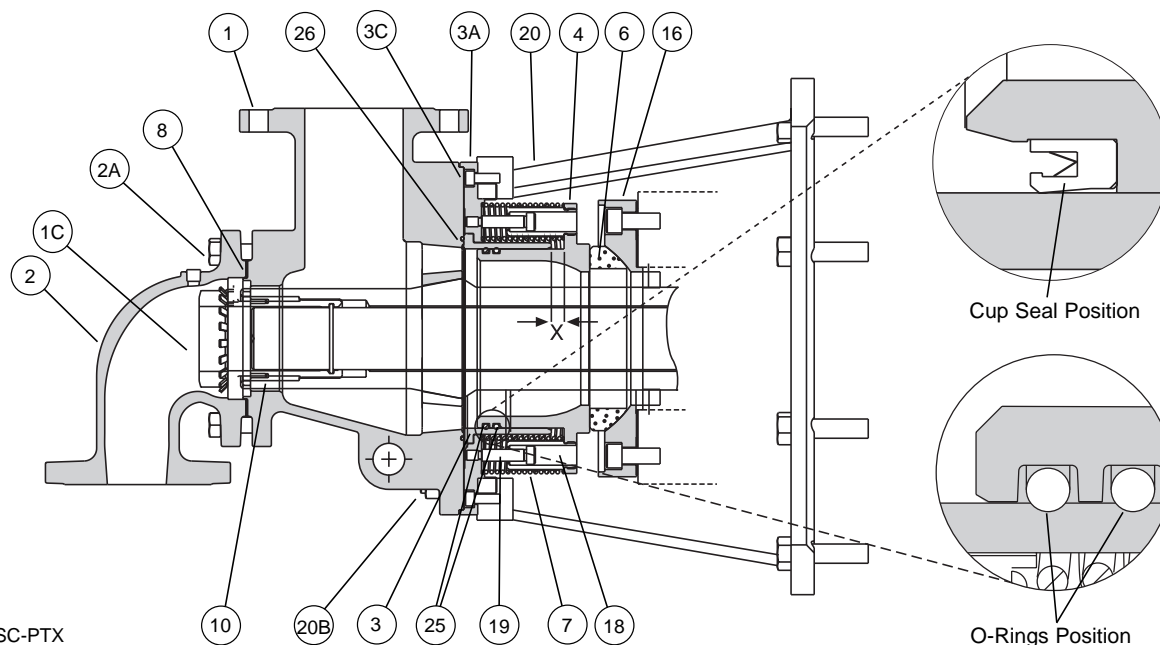

9800AFYSC-PTX

**STEP 9.**

Inspect the shoulder screws (19), torque tubes (18) and springs (7). Replace if worn or damaged.

**STEP 10.**

Inspect the bore of end cap (3). It is an o-ring sealing surface and should be smooth. If worn or steam cut, replace it. Remove the end cap by removing two end cap retaining screws (3B). Separate the end cap from the end flange (3A). Install a new end cap by reversing this procedure.

**STEP 11.**

Remove gasket (8), and clean all gasket material from mating surfaces on body (1) and head (2). Clean all parts as necessary.

**REASSEMBLY AND REINSTALLATION:**

**STEP 12.**

Place the end cap/end flange assembly (3, 3A, & 3B) back into the press. Position the springs into the counter bores that are machined into end flange. Install new o-rings or cup seal (25) onto the nipple (4). The cup seal must be positioned with cup or U-shaped portion facing the system pressure (see balloon detail). Lubricate the cup seal or o-ring and the bore of the end cap with silicone lubricant. Position the nipple over the springs, passing the torque tubes into the springs. Carefully align the nipple with the bore of the end cap. Note: The end cap is designed to accept the o-rings or the lip of the cup seal and will aid in compressing them as the nipple is pushed into the end cap. With the press, push the nipple into the end cap watching the o-rings or the lip of the cup seal to make sure they flow into the end cap without twisting or cutting. Apply Loctite to the shoulder bolts (19), install, and tighten. Fully release the press and allow nipple to be held in place by the torque tubes. Turn the assembly over and check the cup seal to make sure the lips did not curl or fold during installation.

**STEP 13.**

Position a new carbon seal ring (6) into the recess of the wear plate (16). Position the end cap assembly into the ring bracket (20) while holding onto the seal ring. Install end cap retaining bolts (3C) and tighten. This will compress the nipple (4) into the end cap creating the X dimension. The X dimension should be  $0.5'' \pm 0.25''$  at this time. When used with CARB bearings, the X dimension is  $0.75'' \pm 0.25''$ . Make sure the seal ring is centered on the flat face of the nipple.

**STEP 14.**

Lubricate a new o-ring (26) with silicone lubricant and place it into the face groove on the joint body (1). Apply Never Seize to the tapered portion of the cantilever support tube. Position the body over the cantilever support tube. Align the pins (10) in the body with the support tube indexing slots. Lift the body and support tube and position them over the studs on the ring bracket. Secure the body to the bracket with hex nuts (20B).

**STEP 15.**

Bend two lockwasher taps that will fit into the holes in the body and install the lockwasher. Apply Never Seize, install the hollow bolt and new o-ring (if equipped) into the cantilever support tube, and tighten. The hollow bolt should be torqued to 300 ft-lbs for the 9750 PTX and 400 ft-lbs for the 9800 PTX rotary joint. Bend two lockwasher tabs over the bolt flats in a manner that will prevent the hollow bolt from loosening.

**STEP 16.**

Reattach the head (2) to joint body (1) using new gasket (8). Connect piping and open valves. The Kadant Johnson joint is now ready to be placed back in service.

*Dimensions are for reference only and subject to change. Certified drawings are available on request. Please refer to Kadant Johnson Drawing Number A37640 for torque specifications.*

The Kadant Johnson Warranty

Kadant Johnson products are built to a high standard of quality. Performance is what you desire: that is what we provide. Kadant Johnson products are warranted against defects in materials and workmanship for a period of one year after date of shipment. It is expressly understood and agreed that the limit of Kadant Johnson's liability shall, at Kadant Johnson's sole option, be the repair or resupply of a like quantity of non-defective product.



www.kadantjohnson.com