

Disassembly and Repair of 9750 PT Joint with Cantilever Syphon

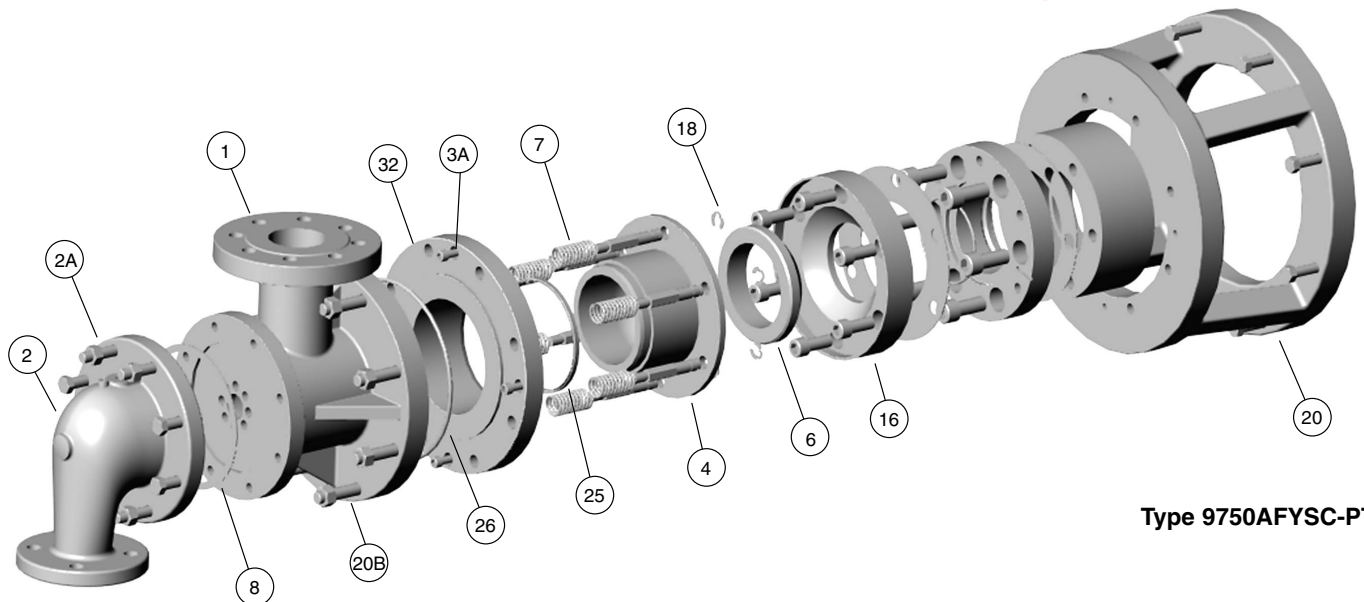

Type 9750AFYSC-PT

REPAIR KITS ARE AVAILABLE CONSISTING OF:

Item #	Qty	Description
6	1	Carbon Seal
8	1	Gasket
25	2	O-Ring
26	1	O-Ring
--	1	O-Ring Lube

NOTE: Please follow your company's safety procedures whenever working on Kadant Johnson Rotary Joints and read all of the instructions completely before proceeding.

Please refer to the assembly drawings supplied with your Kadant Johnson Rotary Joint for part identification. If you have any further questions, please contact your Representative or Kadant Johnson.

REMOVAL AND DISASSEMBLY:

STEP 1.

Close the inlet and outlet valves and allow the joint to cool down. Disconnect the inlet and outlet piping from the joint. Be careful of any pressure still in the system as this may be dangerous.

STEP 2.

Remove head bolts (2A) and head casting (2).

STEP 3.

Remove the four bolts (1C) that hold the cantilever syphon tube (40) to the joint body (1). Install two 9/16" bolts (head bolts, 2A) as jacking screws into the threaded holes (1C) and turn to push the syphon support tube out of its locking taper. See page 2 for part identification.

STEP 4.

To remove the body (1), first remove hex nuts (20B). At this time, be prepared to support the weight of the joint body. Remove body. Discard the large o-ring (26) that is located between the body and the end cap (32).

STEP 5.

Fasten Syphon Retracting Tool RT-6750 to end of syphon support tube (40) using four bolts that are supplied with the tool. Push syphon tube back until it is even with end of dryer journal. Unbolt tool, and set aside for later use.

NOTE: If dryer is equipped with spoiler or Turbulator™ bars, first rotate the support tube 180°, so the syphon foot falls away from dryer shell, making it possible to push syphon into dryer.

SERVICING THE JOINT:

STEP 6.

Remove socket head cap screws (3A) that hold the end cap (32) to the ring bracket (20). As the screws are loosened, the carbon seal ring (6) will be free to fall out of the cavity in the wear plate (16).

STEP 7.

Inspect the wearing surfaces of the wear plate for scratches and wear. Replace if necessary. The wear plate is not part of the repair kit – but it can be ordered separately.

STEP 8.

Remove the nipple (4) from the end cap (32) by placing the assembly in a small press with the nipple wear surface facing up. Place a wooden block on the nipple wear surface to protect it. Push downward on the nipple to compress the springs (7), then remove the retainer rings (18). Release the press, and the nipple will slide out of the end cap.

STEP 9.

Remove nipple o-rings or teflon lip seal (25) and discard. Inspect the nipple sealing surface for damage or wear. Replace if necessary. The nipple is not part of the repair kit – but it can be ordered separately. Using solvent and mild abrasive, clean the grooves and their adjacent sealing surfaces. If pitted or steam cut, replace the damaged part.

If there is a teflon lip seal in position 25, skip Step 10 and go to Step 11.

STEP 10.

Install two new o-rings (25) and apply silicone lube to the o-rings and sealing surfaces for ease of installation.

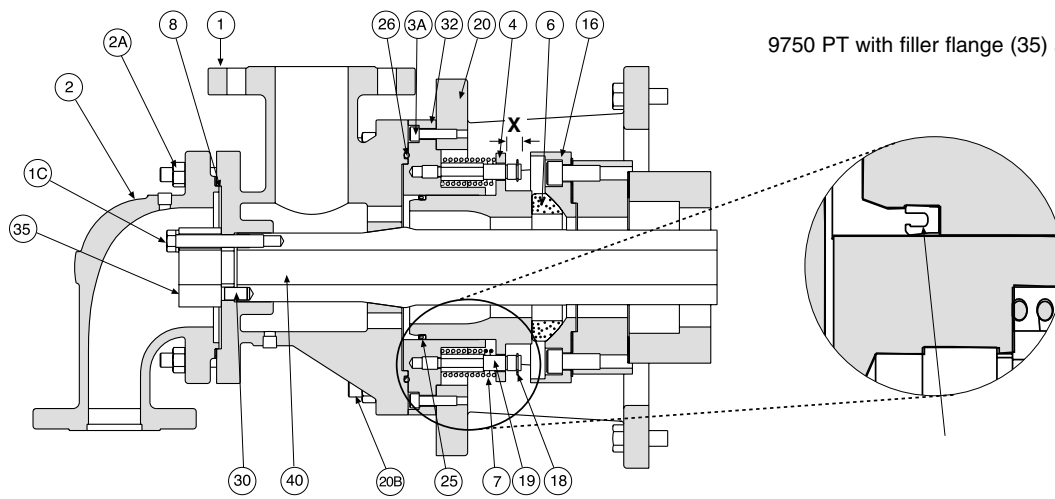
**STEP 11.**

Examine the springs (7) on the end cap (32). If the springs have taken a slight set and are no more than a 1/4" shorter in length than a new spring, they may be reused.

STEP 12.

Remove old gasket (8), and clean all gasket material from mating surfaces on body (1) and head (2).

REASSEMBLY AND REINSTALLATION:

If there is a teflon lip seal in position 25, skip Step 13 and go to Step 13A.

STEP 13.

Place the end cap (32) back into the press with the guide pins (19) facing up. Place the springs (7) over the guide pins (19). Position the nipple (4) back into the bore of the end cap (32) and align the holes in the nipple flange with the spring guide pins. While protecting the sealing (flat) surface of the nipple push the o-rings and nipple into the end cap bore, recompressing the springs and secure with the retaining rings (18).

STEP 13A.

Place the end cap (32) back into the press with the guide pins (19) facing up. Make sure of the end cap bore opposite the guide pins is clear. Place the springs (7) over the guide pins (19). Position the nipple (4) into the bore of the end cap (32) and align the holes in the nipple flange with the spring guide pins. While protecting the sealing (flat) surface of the nipple, push the nipple into the end cap bore, compressing the springs and install the retaining rings (18). Continue to push the nipple through the bore of the end cap until the teflon lip seal groove is exposed. Install the lip seal with the cup or U shaped portion facing the steam (down). Lubricate the lip seal with silicone lubricant. Slowly release the press, this will draw the lip seal into the end cap bore, be careful not to damage the lip seal. Fully release the press so the nipple flange rests against the retainer rings.

STEP 14.

Position a new carbon seal ring (6) into the recess of the wear plate (16). Position the end cap assembly (4-32) into the ring bracket (20) while holding onto the seal ring. Install end cap retaining bolts (3A) and tighten. This will compress the nipple (4) into the end cap. The X dimension should be $.450 \pm .050$ " at this time. Make sure the seal ring is centered on the flat face of the nipple.

NOTE: As the carbon seal ring wears, the space between the retainer ring and the nipple will decrease to zero. When this occurs, the joint will start to leak – however, the metal wearing surfaces will not be in contact with each other.

STEP 15.

Syphons purchased after April 1, 2000 include a groove pin (30) and filler flange (35). If the joint body housing includes a clearance hole, insert the groove pin into the reamed hole in the horizontal support tube (40) and position in the six-o'clock position.

Reattach Syphon Retracting Tool RT-6750 to the support tube (40) and pull the tube back out of the journal until the tapered section is even with the end of the end cap (32). Be sure the syphon has been returned to the down position (6 o'clock). Disconnect Syphon Retracting Tool.

STEP 16.

Place a new o-ring (26) into the face groove on the joint body (1). A few dabs of silicone grease in the groove will hold the o-ring in place while you position the body on the support bracket (20). Once in position, secure the body to the bracket with hex nuts (20B).

For equipment purchased after April 1, 2000, ensure the groove pin (30) is aligned with the hole in the body (1) prior to securing the body to the support bracket (20). If the body (1) does not include a clearance hole, disregard this instruction.

STEP 17.

Reinstall the four support tube locking bolts (1C) and tighten. Tighten grade 8 bolts to 105 ft-lbs or tighten grade 5 bolts to 85 ft-lbs.

For equipment purchased after April 1, 2000, engage the four bolts through the filler flange (35) and into the horizontal support tube (40). Torque the grade 8 bolts to 105 ft-lbs.

STEP 18.

Reattach the head (2) to joint body (1) using new gasket (8). Hook up piping and turn valves on. The Kadant Johnson Joint is now ready to be placed back in service.

Dimensions are for reference only and subject to change. Certified drawings are available on request. Please refer to Kadant Johnson Drawing Number A37640 for torque specifications.

The Kadant Johnson Warranty

Kadant Johnson products are built to a high standard of quality. Performance is what you desire: that is what we provide. Kadant Johnson products are warranted against defects in materials and workmanship for a period of one year after date of shipment. It is expressly understood and agreed that the limit of Kadant Johnson's liability shall, at Kadant Johnson's sole option, be the repair or resupply of a like quantity of non-defective product.

KADANT
JOHNSON

www.kadantjohnson.com