

Disassembly and Repair of Type 2800 and 2950 ELSNARQ Thermal Oil Joints (Without An Assembly Plate)

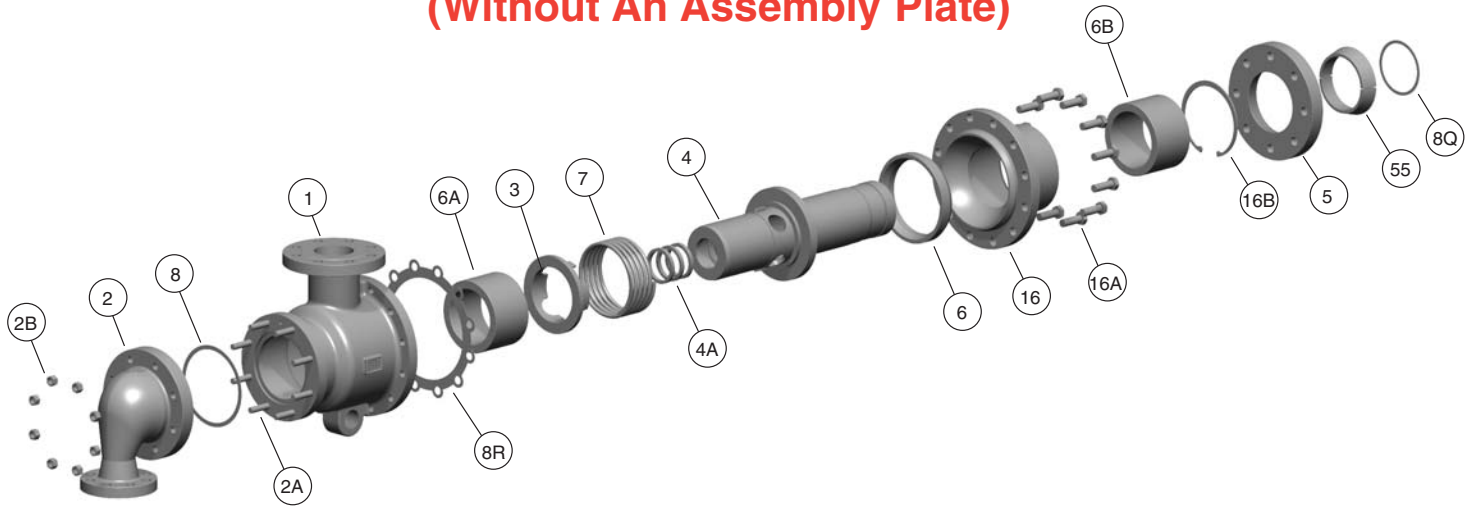

Follow your company's safety procedures whenever working on Kadant Johnson products. Read all of the instructions before proceeding with installation or repair.

Please refer to the Kadant Johnson assembly drawing for part identification. Assembly drawings are available on request from Kadant Johnson.

Lubricate all fasteners with anti-seize compound. Tighten all fasteners in a star pattern. Torque specifications are listed on the product assembly drawing and are available from Kadant Johnson.

REPAIR KITS ARE AVAILABLE CONSISTING OF:

Item #	Qty	Description
4A	3	Packing
6	1	Seal Ring
6A	1	Inboard Guide
6B	1	Outboard Guide
8	1	Gasket
8R	1	Gasket

REMOVAL:

STEP 1.

Close the inlet and outlet valves and allow the joint to cool down. Disconnect the piping from the joint, remove the anti-rotation device.

STEP 2.

Remove the head (2) by removing the hex nuts (2B). If optional packing gland is used, loosen the locknut and remove the packing gland. See Figure 2.

STEP 3.

Remove hex nuts allowing quick release nipple flange (5) to slide away from the journal flange, exposing the two tapered split wedges (55). Remove the rotary joint from the machine for rebuilding. Separate the wedges and remove quick release

nipple flange. Save the split wedges and quick release nipple flange for reuse. Remove and discard metal gasket (8Q).

SERVICING THE JOINT:

STEP 4.

Please use caution while performing this step. There is spring force present under wear plate (16). Remove two hex head cap screws from the wear plate (16A). Secure the wear plate by using two M16 x 6" all thread rods and nuts (See Figure 1), or place joint in a press and hold the wear plate in position. Remove remainder of hex head cap screws. Back off nuts or release the press that is holding the wear plate. The wear plate gasket (8R) may cause wear plate to stick. Loosen the wear plate as spring tension is released. Inspect the seal ring contact area on the spherical surface of the wear plate. If this surface is scratched or grooved, replace the wear plate. Remove retaining ring (16B), freeing outboard guide (6B).

STEP 5.

Remove seal ring (6) from nipple (4). Remove nipple from body (1), slide spring (7) and spring shoulder (3) off the nipple. Remove retaining ring (16B) and slide guide (6A) out of body (1).

STEP 6.

Check the spring shoulder (3) for wear on keyways and the flat sealing surface. Replace spring shoulder if damaged.

STEP 7.

Remove o-rings or packing (4A) from end of nipple (4) and discard them. Inspect the nipple sealing and guide surfaces for scratches, grooves, or pits. Inspect the keys on the nipple for wear. If there is deterioration in these areas, replace the nipple.

STEP 8.

Clean all parts and gasket surfaces.

STEP 9.

Inspect the body (1) guide surface. Replace body if damaged. Slide new inboard guide (6A) into body. Install the retaining ring (16B).

STEP 10.

Place two new lubricated o-rings or packing (4A) in nipple (4) (unless optional packing gland is used). Lubrication is not necessary with packing or packing gland. See Figure 2. Slide spring (7) and spring shoulder (3) onto nipple, lining up keyways. Slide nipple (4) into body (1). Install new seal ring (6) on the nipple in its proper position with the seal ring flat face against the nipple shoulder.

STEP 11.

Insert new outboard guide (6B) into wear plate (16) and secure with retaining ring (16B). Place new gasket (8R) onto body (1). Place wear plate (16) over nipple (4) and onto body. Compress spring/wear plate assembly using method from Step 4. Secure wear plate into position with bolts (16A).

REINSTALLATION

STEP 12.

Place a new metal gasket (8Q) into the recess of the journal.

STEP 13.

Place 'Q' nipple flange (5) over nipple (4) with the taper facing outward. Place the two tapered split wedges (55) into the recess of nipple and secure into position by sliding the 'Q' nipple flange over the wedges.

STEP 14.

Position the joint with quick release flange/nipple assembly (4, 5, and 55) pointed towards the journal flange or roll end. Slide the joint over the horizontal pipe until the pipe passes through

the o-rings or packing (4A). Insert the nipple into the journal flange counterbore. Slide the quick release nipple flange (5) over the journal flange studs and secure flange with hex nuts. Tighten hex nuts evenly. The end of the horizontal pipe should extend 3/8" (10 mm) past the end of the nipple or optional packing gland if used. See Figure 2.

Note: The 'Q' flange will not fit tightly against the journal flange. There should be 1/8" to 3/16" (3 mm to 5 mm) space between the flanges. Make certain this gap is equal around the circumference of the flange.

STEP 15.

If optional packing gland is used, insert new packing rings into the nipple and around the horizontal pipe. Tighten optional packing gland to 30 ft-lbs (41 Nm). Tighten locknut. The horizontal pipe should extend 3/8" (10 mm) beyond the packing gland or the end of the nipple. See Figure 2.

STEP 16.

Install head (2) with new gasket (8). Tighten the hex head nuts (2B) to the proper torque using a star pattern sequence. Rotate joint dry with zero psi, 50-100 rpm for 10 minutes to condition the seal. Caution! Do not exceed 100 rpm or damage may result. Reconnect the piping, turn valves on and joint will be ready for service.

Please refer to Kadant Johnson Drawing Number A37640 for recommended torque specifications.

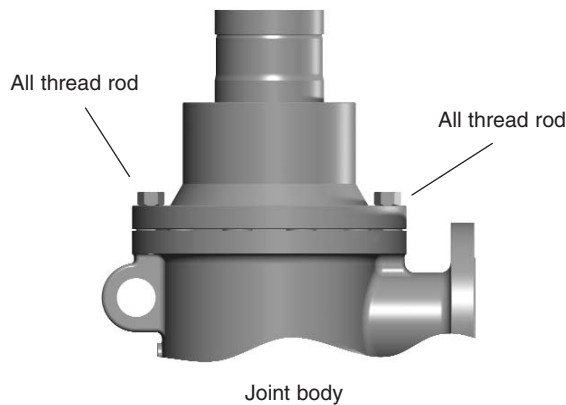
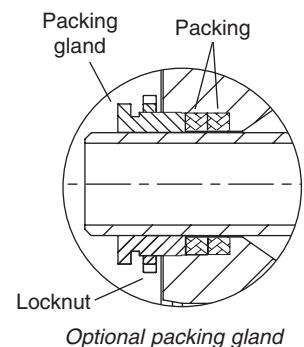
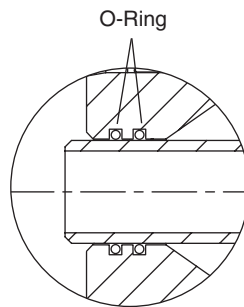
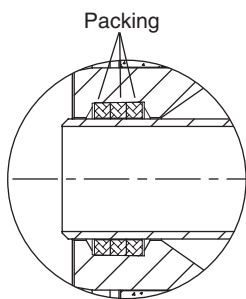

Figure 1

Packing and O-Ring Configurations Figure 2



The Kadant Johnson Warranty

Kadant Johnson products are built to a high standard of quality. Performance is what you desire: that is what we provide. Kadant Johnson products are warranted against defects in materials and workmanship for a period of one year after date of shipment. It is expressly understood and agreed that the limit of Kadant Johnson's liability shall, at Kadant Johnson's sole option, be the repair or resupply of a like quantity of non-defective product.

KADANT
AN ACCENT ON INNOVATION
www.kadant.com