

# Disassembly and Repair of Type LJ Joints

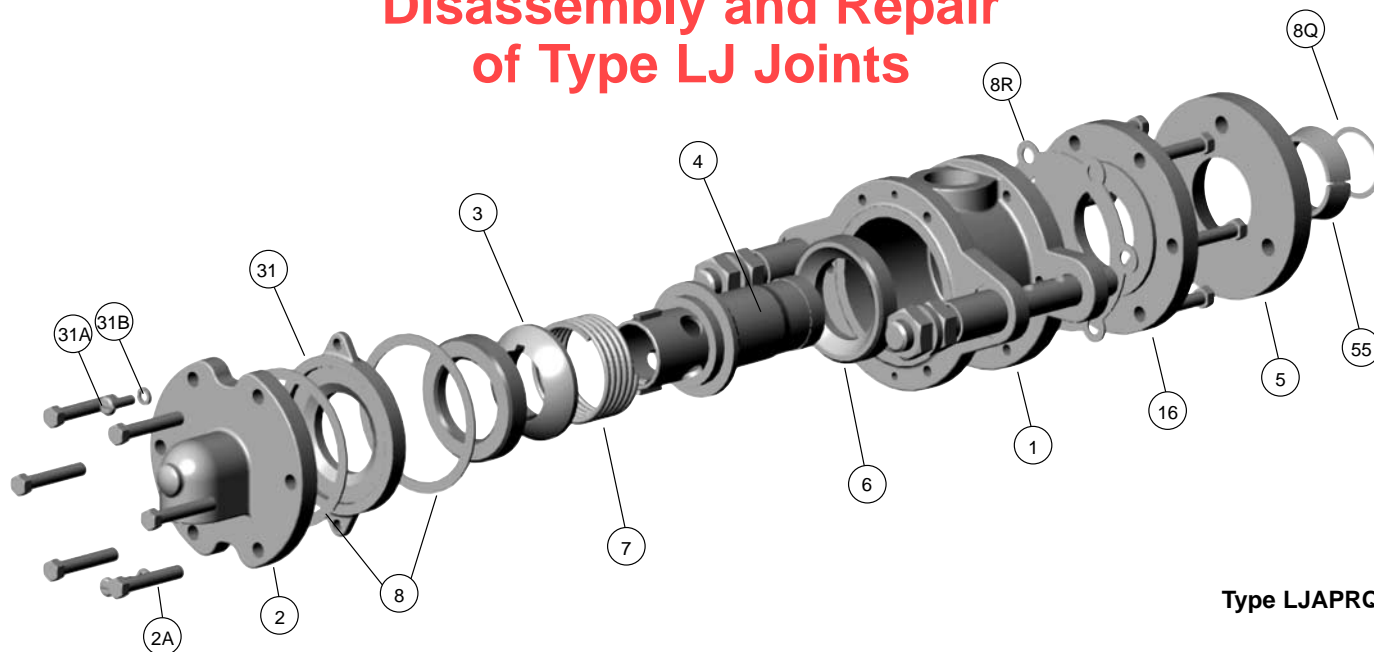

Type LJAPRQ

## REPAIR KITS ARE AVAILABLE CONSISTING OF:

Item #	Qty.	Name
6	2	Carbon Seal Ring
8	2	Gasket
8Q	1	Copper Gasket
8R	1	Gasket - Full Face

**NOTE:** Please follow your company's safety procedures whenever working on Kadant Johnson rotary joints and read all of the instructions completely before proceeding.

Please refer to the assembly drawings supplied with your Kadant Johnson rotary joint for part identification. If you have any questions, please contact your Kadant Johnson Representative or Kadant Johnson.

## REMOVAL:

### STEP 1.

Before performing this step make sure that any residual pressure is released from the system. Close the inlet and outlet valve. Allow the joint to cool sufficiently. Disconnect the inlet and outlet piping from the joint.

### STEP 2.

Remove outlet head bolts (2A) freeing head (2) from the body. Tie or secure it to any adjacent support so that the flexible metal hose is not strained or bent.

### STEP 3.

Remove the hex nuts from the studs at quick release nipple flange (5).

### STEP 4.

Remove the hex nuts from the end of each support rod.

### STEP 5.

If so equipped, remove the support stands that hold the rotary joint in place.

### STEP 6.

The rotary joint should now be free to slide away from the machine. Discard copper gasket (8Q) from the journal flange.

### STEP 7.

Remove 'Q' nipple flange (5) and its two split tapered wedges (55). Be sure to keep the split wedges for reuse.

The joint is now ready for disassembly.

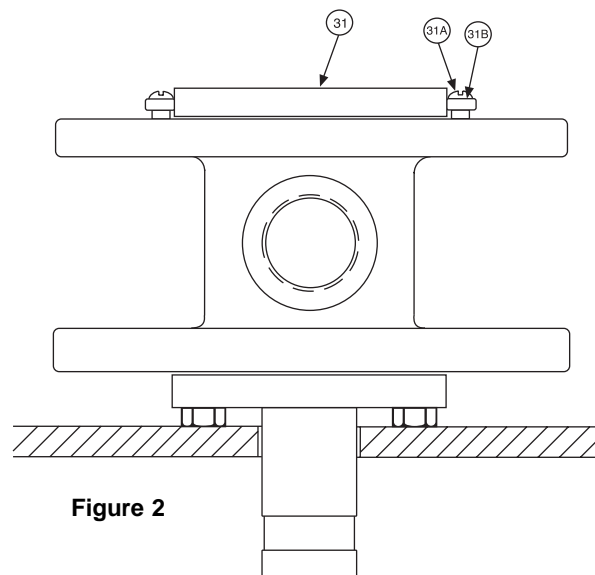

Figure 2

## DISASSEMBLY:

### STEP 8.

Position the rotary joint upright (see Fig. 2) with nipple (4) extending down into a piece of pipe or through a hole in the workbench. In that position, the joint body housing (1) will be resting on wear plate (16).

In the next step you will be removing the two assembly plate screws (31A). The internal joint spring force is contained by the assembly plate (31); be alert as its force is released.

**STEP 9.**

Using a small press apply pressure on thrust collar (3) while removing the two round head screws (31A). Remove the two screws and break loose the gasket. Release the press.

**STEP 10.**

Lift off assembly plate (31) exposing the internal parts. If the parts are stuck together, there may still be spring force present.

**STEP 11.**

Remove the first carbon seal (6), thrust collar (3), spring (7), nipple (4), and the second carbon seal, (also 6).

**STEP 12.**

Inspect the metal wear surfaces for scratches, grooving and pitting. They are: wear plate (16), nipple (4), thrust collar (3) and assembly plate (31). Replace any of these items if any of the above exist.

**STEP 13.**

Clean all gasket surfaces.

**REASSEMBLY:****STEP 14.**

Place a new carbon seal ring (6), (concave side facing outward) into the body housing.

**STEP 15.**

Set nipple (4) into the body housing followed by spring (7) and thrust collar (3).

**STEP 16.**

Place gasket (8) on body opening.

**STEP 17.**

Place carbon seal (6) on top of thrust collar (3) followed by assembly plate (31).

**STEP 18.**

Using the body inlet opening as a viewing port, make sure the keyways in the thrust collar are aligned with the keys on the nipple tube. Using the press, recompress the spring. Then attach assembly plate (31) to body (1) with the two round head screws and lockwashers (31A & 31B).

**REINSTALLATION:****STEP 19.**

Slide 'Q' nipple flange (5) over nipple (4) with its taper facing away from the body.

**STEP 20.**

Place the two tapered wedges in the groove around nipple (4) then slide 'Q' nipple flange (5) over them to hold in place.

**STEP 21.**

Place a new copper gasket (8Q) into the recess of the journal flange.

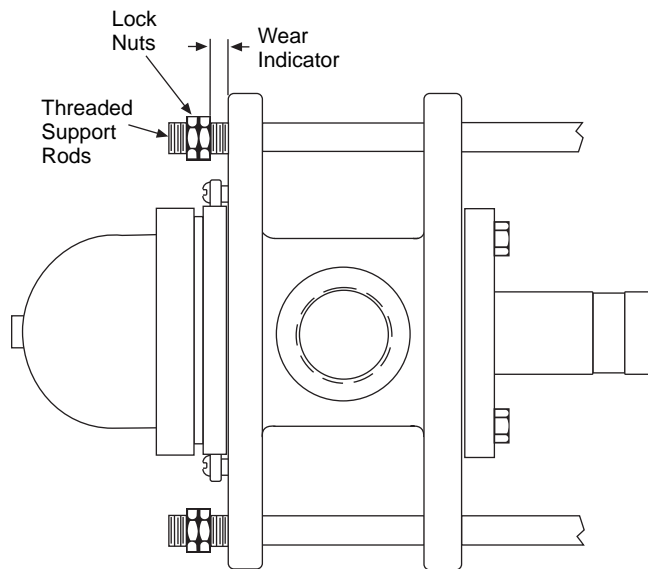
**Figure 3****STEP 22.**

Lift the joint up and slide it over the syphon pipe until its nipple seats against copper gasket (8Q) and 'Q' nipple flange (5) is aligned over the studs of the journal flange. Loosely bolt the rotary joint housing to the support bracket at this time.

**STEP 23.**

Thread the hex nuts onto the journal flange studs and tighten evenly. The 'Q' nipple flange (5) will not seat flush against the journal flange. There will be 1/8" to 3/16" space. Measure this space to make sure it is equal around the circumference of the flange.

**STEP 24.**

Thread the horizontal pipe into outlet head casting (2) and bolt the head to the body housing.

**NOTE:** This style rotary joint is supported by external support rods and it is very important that the joint be centered on the axis of the journal. Check the space or gap between the wear plate opening and the joint's nipple. It should be even. Also check the opening around the thrust collar before reattaching the outlet head fitting.

**STEP 25.**

Once the rotary joint is in position and properly aligned, reset the wear indicators, i.e., set the hex nuts on each support rod to the prescribed distance (consult joint drawing for specification) away from the rotary joints outboard lugs (see Fig. 3). As the carbon seal rings wear this space will decrease.

**STEP 26.**

Clean the gasket surface on head (2), install a new gasket (8) and secure in place with the hex head cap screw.

Reattach the piping and open the valves. The Kadant Johnson joint is now ready to be placed back in service.

**The Kadant Johnson Warranty**

Kadant Johnson products are built to a high standard of quality. Performance is what you desire: that is what we provide. Kadant Johnson products are warranted against defects in materials and workmanship for a period of one year after date of shipment. It is expressly understood and agreed that the limit of Kadant Johnson's liability shall, at Kadant Johnson's sole option, be the repair or resupply of a like quantity of non-defective product.

**KADANT**  
JOHNSON

www.kadantjohnson.com