

Disassembly and Repair of Type 1150LN Joints

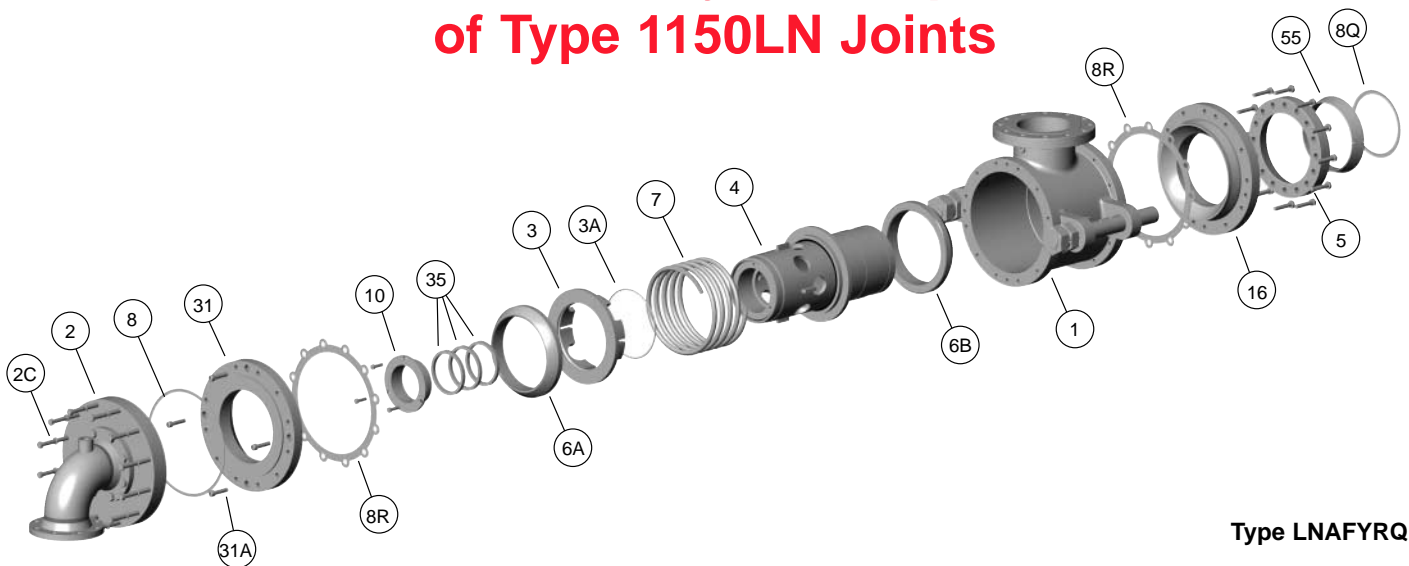

Type LNAFYRQ

REPAIR KITS ARE AVAILABLE CONSISTING OF:

Item #	Qty.	Name
6	2	Carbon Seal Ring
8	1	Gasket
8Q	1	Copper Gasket
8R	2	Gasket - Full Face
35	3	Packing

NOTE: Please follow your company's safety procedures whenever working on Kadant Johnson rotary joints and read all of the instructions completely before proceeding.

Please refer to the assembly drawings supplied with your Kadant Johnson rotary joint for part identification. If you have any questions, please contact your Representative or Kadant Johnson.

REMOVAL:

STEP 1.

Close the inlet and outlet valves and allow the joint to cool down.

STEP 2.

Disconnect the inlet piping from the joint. Be careful of any residual pressure still in the system this may be dangerous.

STEP 3.

Remove outlet head flange bolts (2C) freeing head flange (2) from the body. Tie or secure it to any adjacent support so that the flexible metal hose is not strained or bent.

STEP 4.

Remove the hex nuts, securing the quick release nipple flange (5).

STEP 5.

Remove the hex nuts from the end of each support rod. In some cases, the support rods may have to be removed in order to remove the joint.

STEP 6.

The rotary joint should now be free to slide out away from the machine. Discard copper gasket (8Q) from the journal flange.

STEP 7.

Remove 'Q' nipple flange (5) and its two split tapered wedges (55). Be sure to keep the split wedges for reuse.

The joint is now ready for disassembly.

DISASSEMBLY:

STEP 8.

Position the rotary joint upright (see Figure 1) with nipple (4) extending down into a piece of pipe or through a hole in the workbench. In that position, the assembly will be resting on wear plate (16).

STEP 9.

Remove the four assembly plate screws (31A). The internal joint spring force is contained by the assembly plate (31). **Note:** Use caution while spring tension is released.

STEP 10.

Lift off assembly plate (31) exposing the internal parts. Remove the gasket (8R).

STEP 11.

Remove the first carbon seal (6A), spring shoulder (3), spring (7), nipple (4), and the second carbon seal (6B). Once on the bench, remove the packing from nipple (4).

STEP 12.

Loosen and remove bolts (16A) and remove the wear plate (16).

STEP 13.

Inspect the metal wear surfaces for scratches, grooving and pitting. They are: wear plate (16), nipple (4), spring shoulder (3) and assembly plate (31). Replace any of these items if they are damaged. Clean all gasket surfaces.

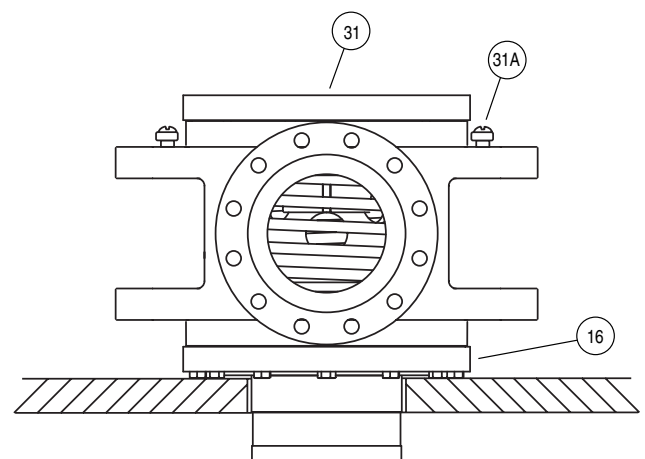

Figure 1

REASSEMBLY:

STEP 14.

Install wear plate, using a new gasket (8R). Torque bolts to 60 ft-lbs.

STEP 15.

Place a new carbon seal ring (6B), (convex side facing inward) into the body housing.

STEP 16.

Place new packing (35) into nipple (4), then install packing gland (10).

STEP 17.

Inspect spring shoulder for pitting or steam cuts. Lubricate with silicone and install a new o-ring (3A) in the spring shoulder (3).

STEP 18.

Set nipple (4) into the body housing followed by spring (7) and spring shoulder (3).

STEP 19.

Place gasket (8R) on body opening.

STEP 20.

Place a carbon seal (6A) on top of spring shoulder (3) followed by the assembly plate (31).

STEP 21.

Using the press, compress the spring. Be sure the keyways in the spring shoulder are aligned with the keys on the nipple tube. Use the body inlet opening as a viewing port. Attach assembly plate (31) to body (1) with the four cap screws (31A).

REINSTALLATION:

STEP 21.

Place a new copper gasket (8Q) into the recess of the journal flange.

STEP 22.

Slide quick release nipple flange (5) onto the rotary joint nipple (4) with its taper facing outward.

STEP 23.

Place the two tapered wedges in the groove around nipple (4) then slide quick release nipple flange (5) over them to hold in place.

STEP 24.

Lift the joint up and slide it over the horizontal pipe until its nipple seats against copper gasket (8Q) and quick release nipple flange (5) is aligned over the studs of the journal flange.

STEP 25.

Thread the hex nuts onto the journal flange studs tightening them evenly. The quick release nipple flange (5) will not seat flush against the journal flange. There will be a 1/16" to 1/8" gap. Measure the gap, it should be the same around the circumference of the flange.

NOTE: This style rotary joint is supported by external support rods and it is very important that the joint be centered on the axis of the journal. Check for clearance at two locations: between the nipple (4) and wear plate (16) and between the nipple (4) and assembly plate (31). The nipple should be centered in the wear plate and centered in the assembly plate. The clearance should be 1/4" (+/- .060") around the entire circumference of the parts in each location. If necessary, adjust sup-

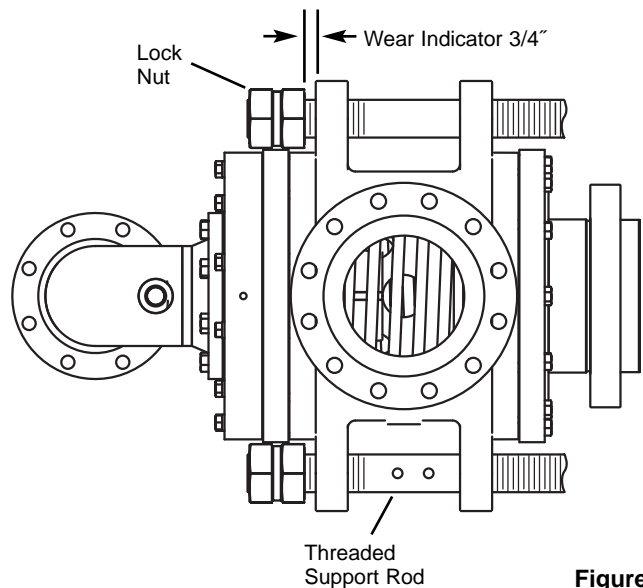

Figure 2

port structure to align joint.

STEP 26.

Once the rotary joint is in position and properly aligned, reset the wear indicators, i.e., set the hex nuts on each support rod 3/4" away from the support lugs (see Figure 2). As the carbon seal rings wear this space will decrease.

STEP 27.

Clean the gasket surface on head flange (2), install a new gasket (8) and secure in place with the hex head cap screw.

Reattach the piping and the rotary joint is ready to be placed back in service.

Dimensions are for reference only and subject to change. Certified drawings are available on request. Please refer to Kadant Johnson Drawing Number A37640 for torque specifications.

PROCEDURE FOR DETERMINING CARBON SEAL RING WEAR.

STEP 1.

The LN rod-supported rotary joint allows for the use of hex nuts on each support rod to provide a visual seal ring wear indicator. See Figure 2.

STEP 2.

Set the location of the hex nut such that the wear indicator distance is 0.75". Using a lock washer and second hex nut, tighten the hex nuts in place. Measure the wear indicator distance again to confirm the measurement is 0.75".

STEP 3.

As the seal ring wears, the rotary joint assembly will move away from the roll to compensate for seal wear. When the rotary joint lug reaches the hex nut, it will no longer be able to move away from the roll, and any additional seal wear will result in a minor steam leak from the back of the rotary joint. When the rotary joint lug reaches the hex nut, the carbon seal ring should be replaced.

The Kadant Johnson Warranty

Kadant Johnson products are built to a high standard of quality. Performance is what you desire: that is what we provide. Kadant Johnson products are warranted against defects in materials and workmanship for a period of one year after date of shipment. It is expressly understood and agreed that the limit of Kadant Johnson's liability shall, at Kadant Johnson's sole option, be the repair or resupply of a like quantity of non-defective product.

KADANT
JOHNSON

www.kadantjohnson.com