

Installation and Service Procedures for a 6000 Series Type Joint with a PTX End Cap

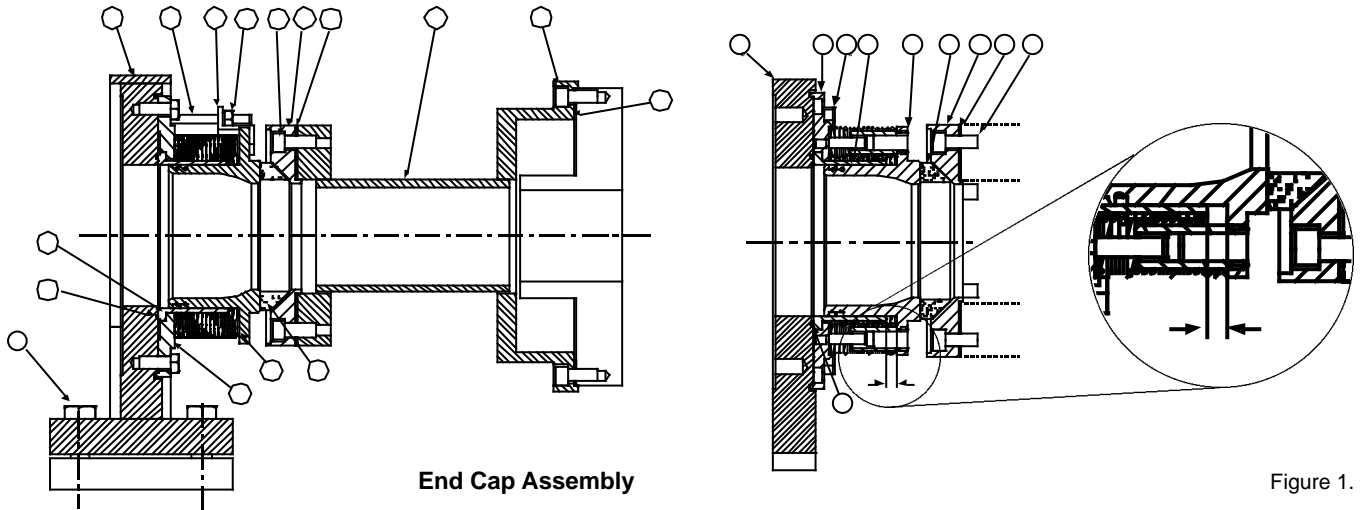

Figure 1.

NOTE: Please follow your company's safety procedures whenever working on Kadant Johnson Rotary Joints and read all of the instructions completely before proceeding.

Please refer to the assembly drawings supplied with your Kadant Johnson rotary joint for part identification. If you have any questions, please contact Kadant Johnson.

Disconnect piping and allow equipment to cool and remove. In some cases it may not be necessary to remove existing journal flange. Please consult your Kadant Johnson Representative if you are not sure.

STEP 1.

Make sure mounting pad for the new rotary joint is clean and that the mounting holes are in their proper location. Check the foot print on the drawing that is supplied with the rotary joint.

STEP 2.

Install journal adapter flange (Item 2A) and gasket (Item 2B) if required. Torque the fasteners (Item 2C) as specified on the drawing accompanying the Kadant Johnson rotary joint.

STEP 3.

Install wear plate (Item 16) and wear plate gasket (Item 8A) on to the journal flange. Torque the fasteners (Item 16A) as specified on the drawing accompanying the Kadant Johnson rotary joint.

STEP 4.

Install two spring compressing tools consisting of Items 8, 9, and 10. See Figure 2. Install two of the threaded rods (Item 9) into the tapped holes provided in the end flange (Item 3 A) 180° from each other. Place "S" shaped bracket (Item 8) over threaded rods and rest one end of it on the nipple flange (Item 4). Thread nuts (Item 10) onto the threaded rod and draw the nipple into the end cap assembly until the "X" dimension is 1/2". See Figure 1.

STEP 5.

Place the seal ring (Item 6) into the recess of the wear plate and hold it in position.

STEP 6.

Place the rotary joint into position on the mounting pad. Push the rotary joint up against seal ring. Adjust the rotary joint as necessary making sure the joint is square to the journal end and the seal ring is centered on the nipple. After aligning the rotary joint secure it into position with the mounting bolts (Item 5).

STEP 7.

Remove both of the spring compressing tools by loosening the nuts. Remove the "S" shaped brackets and threaded rod. When this step is completed, spring force is applied to the seal ring and the joint is ready for piping.

Removing the end cap assembly (Major Items 3, 3A, and 4) for repair.

STEP 8.

Install two spring compressing tools consisting of Items 8, 9, and 10. See Figure 2. Install two of the threaded rods into the tapped holes provided in the end flange (Item 3 A) 180° from each other. Place "S" shaped bracket (Item 8) over threaded rods and rest one end of it on the nipple flange (Item 4). Thread nuts (Item 10) onto threaded rod and draw nipple into end cap until the nipple flange is drawn up to the face of the end cap (Item 3). See Figure 2. As this step is accomplished the seal ring (Item 6) will become loose and fall out of the wear plate (Item 16) recess, prepare to capture it.

STEP 9.

Loosen and remove eight bolts (Item 3C). Remove end cap assembly by passing it between the wear plate (Item 16) and the body (Item 20). In some cases, it may be necessary to loosen the body mounting bolts (Item 5) and move the body

back away from the machine to gain more room between it and the wear plate.

STEP 10.

Remove and discard o-ring (Item 26).

STEP 11.

The end cap is now ready to be serviced. Please follow the instructions outlined in Repair Bulletin No. R-PTX End Cap Bench Repair.

INSTALLING THE END CAP ASSEMBLY.

STEP 12.

Inspect the wear plate (Item 16) surface where the seal ring rides. It should be smooth, not steam cut or scored. Replace wear plate if required.

STEP 13.

Clean the o-ring groove where the o-ring (Item 26) is positioned. Check the groove for pitting or steam cutting. Replace the joint body if the o-ring groove is damaged. Lubricate a new o-ring with Parker Super O-ring Lube to help hold the o-ring in position and place it in the groove.

STEP 14.

Reinstall two spring compressing tools as outlined in Step 8.

STEP 15.

Position a new seal ring (Item 6) into the recess of the wear plate (Item 16) and hold it in position.

STEP 16.

Slide end cap assembly into position between the body and the wear plate. Make sure the o-ring is in position while performing this step.

STEP 17.

Secure the end cap assembly to the body with bolts (Item 3C). Tighten to 135 Nm.

STEP 18.

If the body was removed to aide in end cap assembly removal, move it back into position and secure with mounting bolts.

STEP 19.

Release the spring compression tools and remove the threaded rod.

STEP 20.

Check the joint alignment. Make sure the seal ring is centered on the nipple and joint is square to the machine. Make sure the "X" dimension is correct. After the adjustments are made the joint is ready for service.

Dimensions are for reference only and subject to change. Certified drawings are available on request. Please refer to Kadant Johnson Drawing Number A37640 for torque specifications.

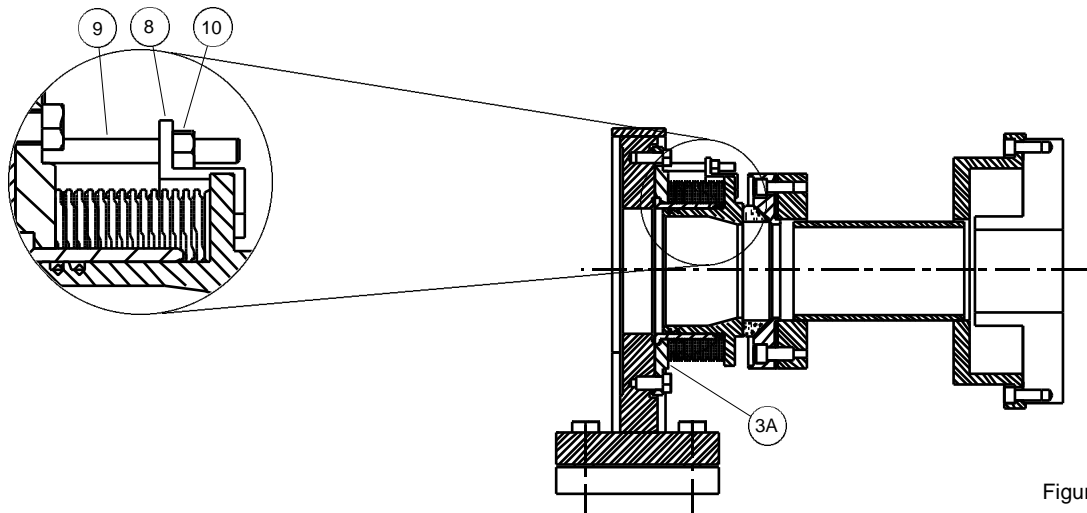

Figure 2.

The Kadant Johnson Warranty

Kadant Johnson products are built to a high standard of quality. Performance is what you desire: that is what we provide. Kadant Johnson products are warranted against defects in materials and workmanship for a period of one year after date of shipment. It is expressly understood and agreed that the limit of Kadant Johnson's liability shall, at Kadant Johnson's sole option, be the repair or resupply of a like quantity of non-defective product.



www.kadantjohnson.com