

Disassembly and Repair of Type 5750SBAF Joints

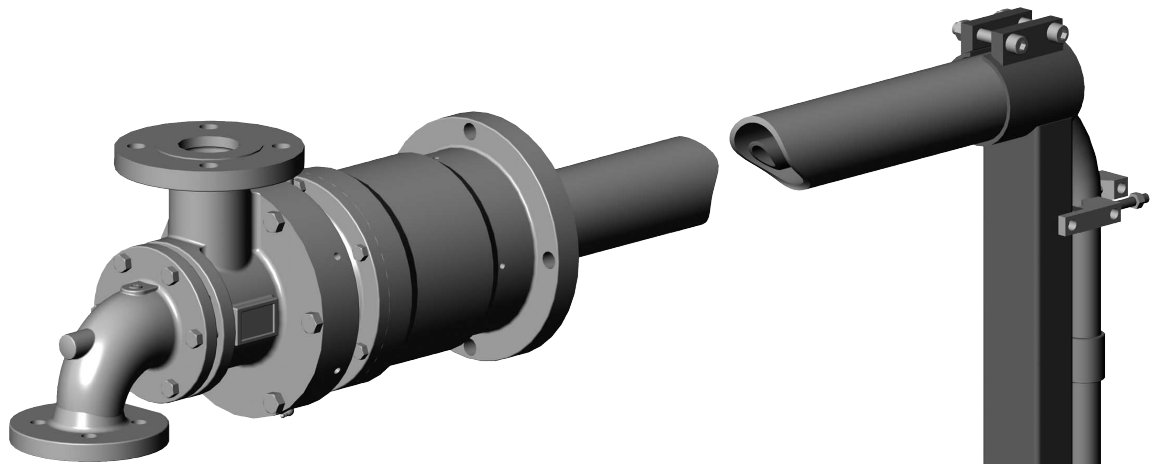

NOTE: Please follow your company's safety procedures whenever working on Kadant Johnson Rotary Joints and read all of the instructions completely before proceeding.

Please refer to the assembly drawings supplied with your Kadant Johnson Rotary Joint for part identification. If you have further questions, please contact Kadant Johnson.

Close the inlet and outlet valves and allow the joint to cool down. Disconnect the inlet and outlet piping from the joint. Be careful of any pressure still in the system as this may be dangerous.

Repair kits are available consisting of:

Item #	Qty	Description
3	2	Bearings
5	1	Seal Ring
6	1	Counterseat Insert
7A	10	Springs
8	1	Gasket
12	1	Counterseat O-Ring
24	1	O-Ring/Cup Seal
-	1	O-Ring Lube
25	1	Lip Seal
26	1	Lip Seal
28	1	O-Ring
CSS825-219AF	1	O-Ring
CSS825-237AF	2	O-Rings

NOTE: Do not use anti-seize or petroleum-based products on o-rings. Only lubricate the o-rings with the silicone lubricant supplied with the Kadant Johnson Repair Kit.

STEP 1.

Remove the six hex head cap screws (Figure 1, Item 32) from the elbow (Figure 1, Item 2A). Remove the elbow and set aside. Discard gasket (Figure 1, Item 8) and clean gasket surface.

STEP 2.

Remove the six hex head cap screws (Figure 1, Item 33) from the head and remove the head (Figure 1, Item 2). Discard o-ring (Figure 1, Item 20) and clean the sealing surface on the pilot of the head.

STEP 3.

Remove the three socket head cap screws (Figure 1, Item 30) from the pipe gland (Figure 1, Item 22). Remove the pipe gland from the head. Discard o-ring (Figure 1, CSS825 -219AF) in pipe gland.

STEP 4.

Bend the tabs of the star lock washer (Figure 9, Item 18) away from the flats of the large hollow bolt (Figure 9, Item 17). Loosen the syphon fastener approximately 6 mm. Using a brass drift or a lead hammer, hit the fastener with a sharp blow. This will loosen the syphon support tube (Figure 9, Item 12) from the taper within the joint. Once the syphon support tube is loosened, remove the large hollow bolt and star lock washer.

STEP 5.

Prepare to support the weight of the joint and remove the bolts (Figure 1, Item 11) that hold the body to the roll. Slide the joint body out of the counterbore on the journal flange and off of the roll over the support tube.

FIGURE 1

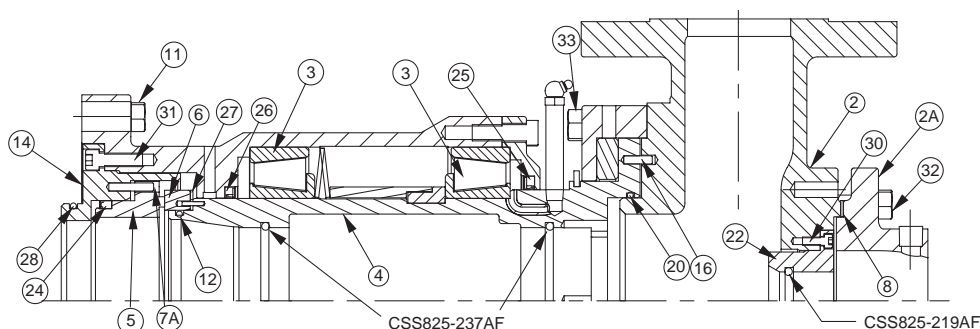

REBUILDING THE JOINT

STEP 6.

Set joint in upright position with flanged end of nipple (Figure 1, Item 4) facing down. To make sure joint is resting securely, use a 160 mm O.D. piece of tubing or round to place joint upon. This will allow joint to be disassembled without removal of groove pins (Figure 1, Item 16). If the groove pins in flanged end of nipple have become loose or bent, remove the existing pins. Replace with new groove pins after the joint is completely repaired.

STEP 7.

Remove the six socket head cap screws (Figure 1, Item 31) from the assembly plate (Figure 1, Item 14). Remove assembly plate and all parts assembled inside and set aside. If assembly plate is difficult to remove, insert two 5/16 -18 screws in two jacking screw holes provided in assembly plate until assembly plate becomes free. Once assembly plate is removed, remove o-ring (Figure 1, Item 28) from pilot and discard.

STEP 8.

Remove counterseat (Figure 1, Item 6) from end of nipple and discard. Remove o-ring (Figure 1, Item 12) and gasket (Figure 1, Item 27) and discard both.

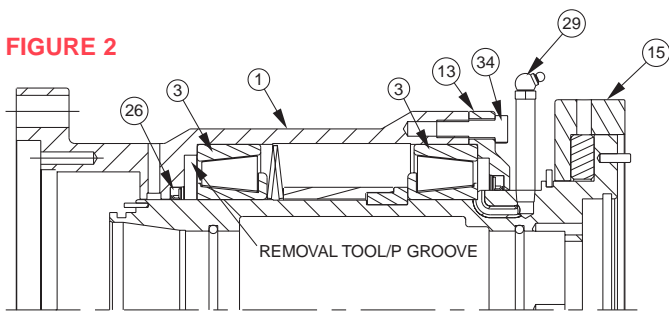

STEP 9.

Remove the two grease fittings (Figure 2, Item 29) and set aside.

STEP 10.

Remove the six hex head cap screws (Figure 2, Item 34) from the retaining plate (Figure 2, Item 13). Slide retaining plate away from body (Figure 2, Item 1) and rest it on nipple retaining plate (Figure 2, Item 15).

STEP 11.

Remove the body by sliding it up and off of bearings (Figure 2, Item 3). A gear puller or press may be required to remove the body. If the outer race of the first bearing remains wedged inside body bore, use the Bearing Removal Tool (57599-IT-5) to remove outer race without damaging body. When using the Bearing Removal Tool, place outer diameter of two split flanges in the groove between body and outer race of bearing. Once both sides are in place, tighten split rings with two washers, one hex head cap screw, and one hex nut (refer to the 57599-IT-5 Assembly Drawing). Once Removal Tool is assembled in place, use a hydraulic press to slowly slide outer race out of body.

STEP 12.

Remove the lip seal (Figure 2, Item 26) from inside body if one is present and discard. Clean body and set aside.

FIGURE 3

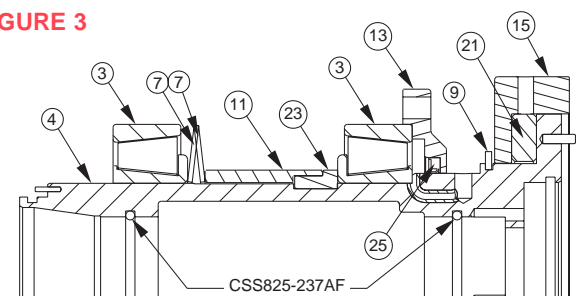

STEP 13.

Remove remaining portion of first bearing (Figure 3, Item 3) by sliding it up and off of the nipple (Figure 3, Item 4). Discard bearing once it is removed.

STEP 14.

Remove two disc springs (Figure 3, Item 7) and the bearing spacer (Figure 3, Item 11). Clean parts and set aside. Remove the pair of split rings (Figure 3, Item 23), clean and set aside.

STEP 15.

Remove remaining bearing and discard.

STEP 16.

Slide retaining plate (Figure 3, Item 13), with lip seal (Figure 3, Item 25) in place, up and off of nipple. Remove lip seal from groove in retaining plate and discard. Clean retaining plate and set aside.

STEP 17.

Remove and discard the two o-rings (Figure 3, CSS825-237AF) from the internal o-ring grooves inside of the nipple. Once o-rings are removed, thoroughly clean inside and outside surfaces. The retaining ring (Figure 3, Item 9), nipple retaining plate (Figure 3, Item 15) and carbon bushing (Figure 3, Item 21) should remain assembled to nipple.

FIGURE 4

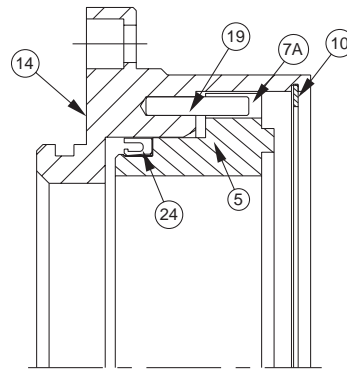

STEP 18.

Place assembly plate (Figure 4, Item 14) on work bench with small pilot down.

STEP 19.

While pressing down on the seal ring (Figure 4, Item 5), remove the retaining ring (Figure 4, Item 10) from the groove in the assembly plate and set aside. Once the retaining ring is removed, slowly release pressure on the seal ring.

STEP 20.

Remove seal ring from bore in assembly plate. The cup seal or o-ring (Figure 4, Item 24) will be assembled in groove on seal ring. Discard both.

STEP 21.

Remove and discard all springs (Figure 4, Item 7A) from inside of assembly plate.

STEP 22.

With two groove pins (Figure 4, Item 19) remaining intact, thoroughly clean all surfaces of assembly plate.

STEP 23.

Inspect the bore that the cup seal or o-ring slides into. If it is damaged, discard the assembly plate.

NIPPLE, ASSEMBLY I

STEP 24.

Remove bearings from packaging, clean bearings, and allow to dry completely.

STEP 25.

Place bearings (Figure 5, Item 3) on clean, flat surface. Fill cavity between each roller with grease. Turn bearing over and repeat for the other side. Refer to joint drawing for grease specification, quantity, and relubrication schedule.

Nipple, Assembly I

FIGURE 5

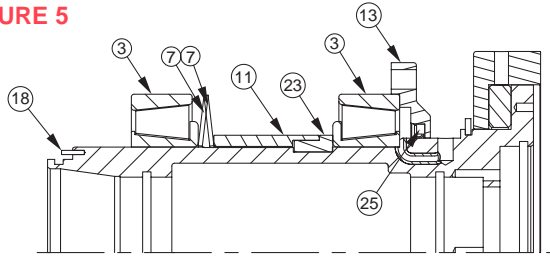

STEP 26.

Heat bearings in oven to 93°C, not to exceed 120°C. Allow sufficient time for even heating.

STEP 27.

Install seal (Figure 5, Item 25) in retaining plate (Figure 5, Item 13) with the lip facing up. A press is recommended for this operation. Apply a small amount of grease to the lip of the seal where it will contact the nipple surface.

STEP 28.

Place nipple on workbench resting on the flange.

STEP 29.

Install retaining plate on nipple. Retaining plate should be installed with lip seal facing up. See diagram above. Put a moderate amount of grease inside the shoulder that the bearing will rest against.

STEP 30.

Remove bearing from oven and install over nipple and position against nipple shoulder. **CAUTION:** Move quickly and install bearing straight or bearing will jam. Be sure the bearing is oriented as shown in Figure 5 and the cup portion of the bearing is in place.

STEP 31.

Place split rings (Figure 5, Item 23) in groove on the nipple with the flanged end resting against the bearings. Place the bearing spacer (Figure 5, Item 11) on the nipple and slide it down until it rests against the flange on the split rings.

STEP 32.

Place two Belleville Washers (Figure 5, Item 7) on the nipple with the orientation shown in Figure 5.

STEP 33.

Remove remaining bearing from oven and place on nipple against spacer.

STEP 34.

Check the two 2,4 mm diameter groove pins (Figure 5, Item 18) in the end of nipple. Be sure they are not bent or "mushroomed". Replace if damaged.

assembly Plate, Assembly II

STEP 35.

Place assembly plate (Figure 6, Item 14) on work bench with small pilot down. Check the two groove pins (Figure 6, Item 19). Replace if worn or damaged.

STEP 36.

Place springs (Figure 6, Item 7A) into remaining holes provided.

STEP 37.

Assemble cup seal or o-ring (Figure 6, Item 24) in groove of seal ring (Figure 6, Item 5) orientated as shown. The springs inside the cup seal should be visible after the seal is installed. Apply O-Ring Lubricant, Kadant Johnson Part No. CSS800-1, to outside of cup seal or o-ring.

STEP 38.

Align the holes in the carbon seal ring (Figure 6, Item 5) with the groove pins (Figure 6, Item 19). Push the seal inward compressing the springs sufficiently to allow the retaining ring (Figure 6, Item 10) room to fit in groove provided in assembly plate. (Use caution when handling seal ring to avoid damage to sealing face.) Be sure the cup seal is not damaged during installation.

Assembly Plate, Assembly II

FIGURE 6

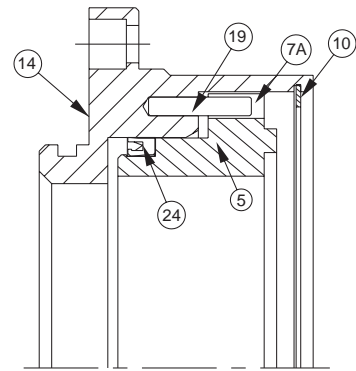

STEP 39.

With springs compressed by seal ring, install retaining ring (Figure 6, Item 10) into groove provided in assembly plate. Slowly release pressure on the seal ring allowing it to move upward and contact the retaining ring. Depress the seal ring several times into the bore and allow it to return to the retaining ring. If it does not return smoothly, disassemble it and determine which part is binding.

FIGURE 7

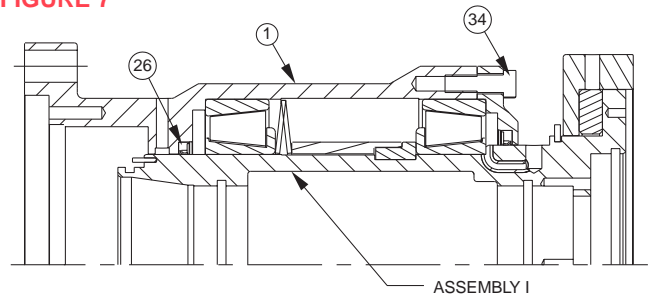

STEP 40.

If the assembly drawing lists Figure 7, Item 26, perform this step. If it does not, continue to Step 41. Install the lip seal (Figure 7, Item 26) in the body (Figure 7, Item 1) using a press. The lip on the seal should be facing up. Apply a small amount of grease to the seal lip.

STEP 41.

Let nipple assembly (Figure 5) cool to room temperature.

STEP 42.

Place nipple assembly on workbench with the flanged end facing down. Place the seal installation tool (57599-IT-1) over the end of the nipple. If Step 18 was not performed, skip this step.

STEP 43.

Slowly slide the body over the nipple assembly. Continue to slide body over nipple assembly until it rests firmly against the upper bearing. Remove Seal Installation tool.

STEP 44.

Attach retaining plate to the body with hex head cap screws (Figure 7, Item 34). Tighten screws to 27 NM of torque.

FASTENER SIZE	TORQUE VALUE (NM)
7/16"	55
1/2"	80
9/16"	120
5/8"	160
3/4"	270

Table 1

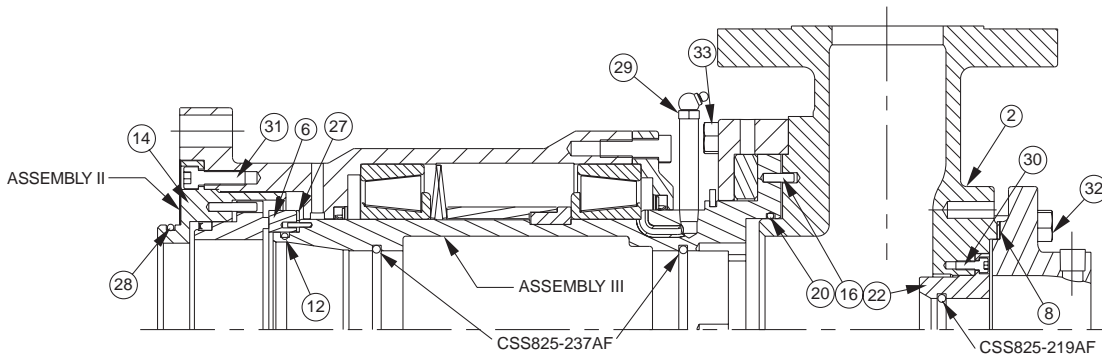

STEP 45.
Place o-ring (Figure 8, Item 12) in groove provided in end of nipple. Use o-ring lubricant to install o-ring making sure no lubricant gets on sealing surface of the seal ring and counterseat. Place gasket (Figure 8, Item 27) on end of nipple.

STEP 46.
Align holes in counterseat (Figure 8, Item 6) with groove pins in end of nipple. Carefully install counterseat onto end of nipple.

CAUTION: This assembly must be square to avoid breaking the counterseat at the pin locations. Clean seal faces with acetone or alcohol using a clean towel.

STEP 47.
Install Assembly II (see Figure 6), careful to avoid any damage to the sealing faces, to Assembly III (see Figure 8) using socket head cap screws (Figure 8, Item 31). Tighten cap screws securely.

STEP 48.
Rotate entire assembly 180° so the assembly plate is resting on workbench. If required, install four groove pins (Figure 8, Item 16) in the holes in end of nipple.

STEP 49.
Install o-ring (Figure 8, Item 20) in gland in end of nipple. Apply o-ring lubricant.
Joint Installation

STEP 50.
Prepare to install the joint by lubricating and installing two o-rings (Figure 8, CSS825-237AF) into the o-ring grooves located inside of the nipple. Lubricate and install a new o-ring (Figure 8, Item 28) onto the assembly plate (Figure 8, Item 14).

STEP 51.
Make sure the support tube from Step 5 is in the proper location with the syphon at the 6 o'clock position. Using Never Seize compound, lubricate the support tube taper

(Figure 9, Item 12) and the end of the support tube where the anti-rotation slots are located. Lubricate the threads of the large hollow bolt (Figure 9, Item 17). Pass the joint over the support tube while aligning the anti-rotation pins in the nipple with the slots in the support tube. When in position, install the star washer (Figure 9, Item 18) and large hollow bolt (Figure 9, Item 17). Be sure that a tab on the star washer is engaged into one of the 3/8" holes in the end of the nipple.

Continue to position the assembly plate/joint body assembly into the counterbore of the journal flange. Align the holes in the body with the tapped holes in the journal flange. Secure body into position with the 5/8" bolts provided using a star pattern and the proper torque listed on the table on the previous page.

STEP 52.
Tighten the large hollow bolt to 170 NM. Bend one of the tabs on the lock washer until it rests securely against the hex portion of the syphon fastener. Verify that the tab is bent against the correct side of the hex to prevent rotation in the counter clockwise direction. If the tab is bent in the wrong location it will allow the fastener to rotate before it hits the tab.

STEP 53.
Install head (Figure 8, Item 2), with o-ring (Figure 8, Item 20) in place and torque lug, on nipple and secure using hex head cap screws (Figure 8, Item 33). Tighten the 1/2" screws using a star pattern and the proper torque listed on the table on the previous page.

STEP 54.
Lubricate o-ring (Figure 8, CSS825-219AF) and install it in pipe gland (Figure 8, Item 22). Install pipe gland in head and secure using socket head cap screws (Figure 8, Item 30). Apply a small amount of thread lubricant to each screw and tighten securely.

STEP 55.
Place gasket (Figure 8, Item 8) over pilot on elbow and install elbow onto the head. Secure with six 1/2" hex head cap screws (Figure 8, Item 32), using a star pattern and the proper torque.

STEP 56.
Install grease fittings (Figure 8, Item 29) in threaded holes on nipple between nipple retaining plate and retaining plate. Pump ten shots of grease as specified on the assembly drawing into each grease fitting.

STEP 57.
The joint is now ready to receive piping.

Dimensions are for reference only and subject to change. Certified drawings are available on request. Please refer to Kadant Johnson Drawing Number A37640 for torque specifications.

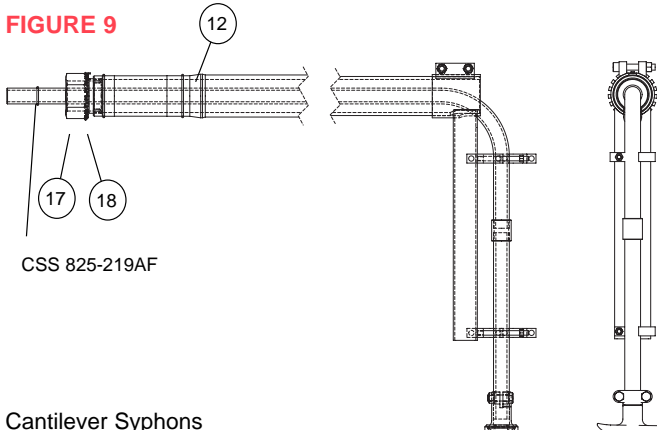

Cantilever Syphons

The Kadant Johnson Warranty

Kadant Johnson products are built to a high standard of quality. Performance is what you desire: that is what we provide. Kadant Johnson products are warranted against defects in materials and workmanship for a period of one year after date of shipment. It is expressly understood and agreed that the limit of Kadant Johnson's liability shall, at Kadant Johnson's sole option, be the repair or resupply of a like quantity of non-defective product.

