

Disassembly and Repair of Type ELSN Joints

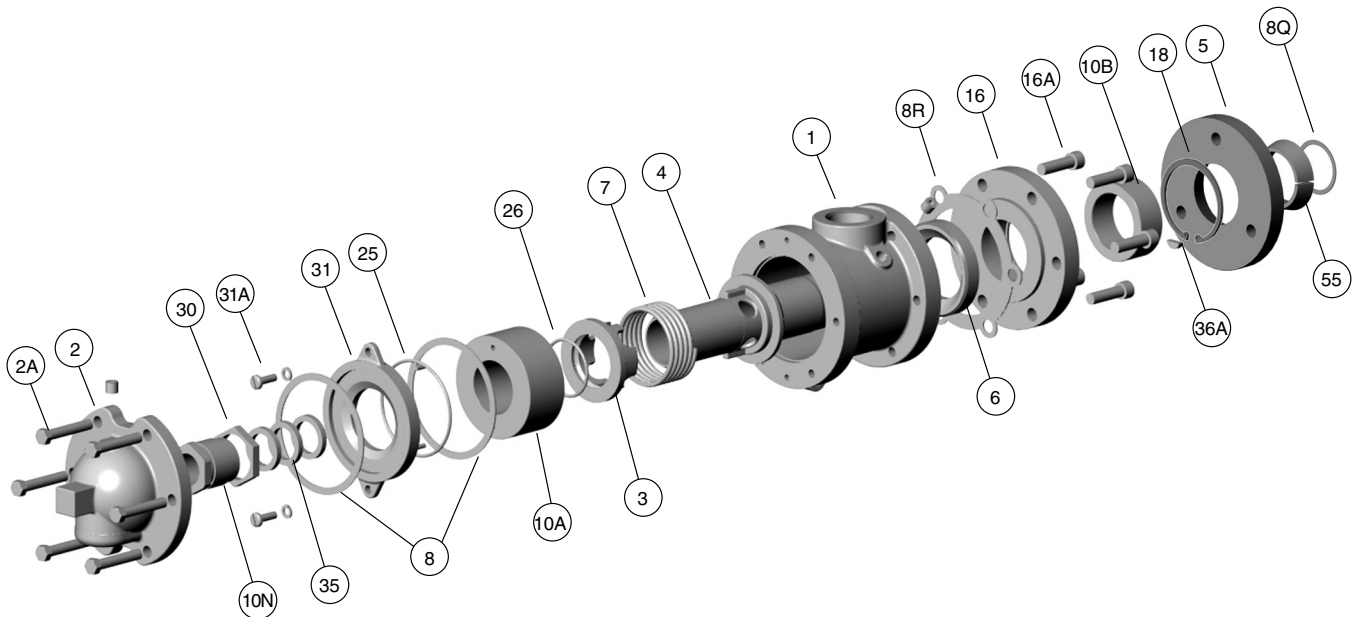

Type ELSNARQ

REPAIR KITS ARE AVAILABLE CONSISTING OF:

Item #	Qty	Description
6	1	Carbon Seal
10A	1	Frnt. Carbon Guide
10B	1	Bk. Carbon Guide
8	2	Gaskets
8R	1	Gasket
25	1	O-Ring
26	1	O-Ring
35	2	Packing

NOTE: Follow all your company's safety procedures whenever working on Kadant Johnson rotary joints.

REMOVAL:

STEP 1.

Close the inlet and outlet valves and allow joint to cool down. Disconnect piping from joint, remove anti-rotation rod and restraining yoke (if used).

STEP 2.

Remove head (2) by removing the hex head cap screws (2A). Loosen the packing gland locknut (30) and remove the packing gland (10N).

STEP 3.

Remove hex nuts allowing flange (5) to slide out, away from the journal flange, exposing the two tapered split wedges (55). You can now pull the rotary joint away from the machine for rebuilding in your shop. Separate the wedges and remove flange (5). Use caution as not to drop the wedges.

SERVICING THE JOINT:

STEP 4.

Loosen and remove the two round head screws (31A) freeing assembly plate (31). Caution is advised as there is spring

tension behind this plate. The assembly plate gasket may be stuck holding this plate in place. Pry loose if required.

STEP 5.

Lift off the assembly plate and remove the remaining parts in the following order: o-ring (25), front carbon guide (10A). Remove nipple (4) assembly consisting of the spring shoulder (3), o-ring (26) and the spring (7). Remove the seal ring (6).

STEP 6.

Separate the wear plate (16) from the body (1) by removing the hex head cap screws (16A). Inspect the flat surface of the wear plate where the seal ring runs against it. If this surface is scratched or grooved, replace the wear plate. If the wear plate is in servicable condition, replace the back guide (10B) by removing the retainer ring (18) freeing the carbon guide. Retain the woodruff key (36A).

STEP 7.

Clean all gasket surfaces.

STEP 8.

Slide the spring shoulder (3) off the nipple tube (4). Located inside of the spring shoulder is an o-ring (26). Remove it and clean its groove with steel wool and solvent. Also clean the o-ring's sealing surface on nipple tube (4).

STEP 9.

Remove the packing (35) from the end of the nipple (4) and discard it. Inspect the nipple's sealing and bearing surfaces for scratches, grooves or pits. If there is deterioration in these areas, replace the nipple.

STEP 10.

On the face of assembly plate (31) is located an o-ring groove. Clean with solvent and steel wool. No scratches or pits should exist. If so, replace with a new part.

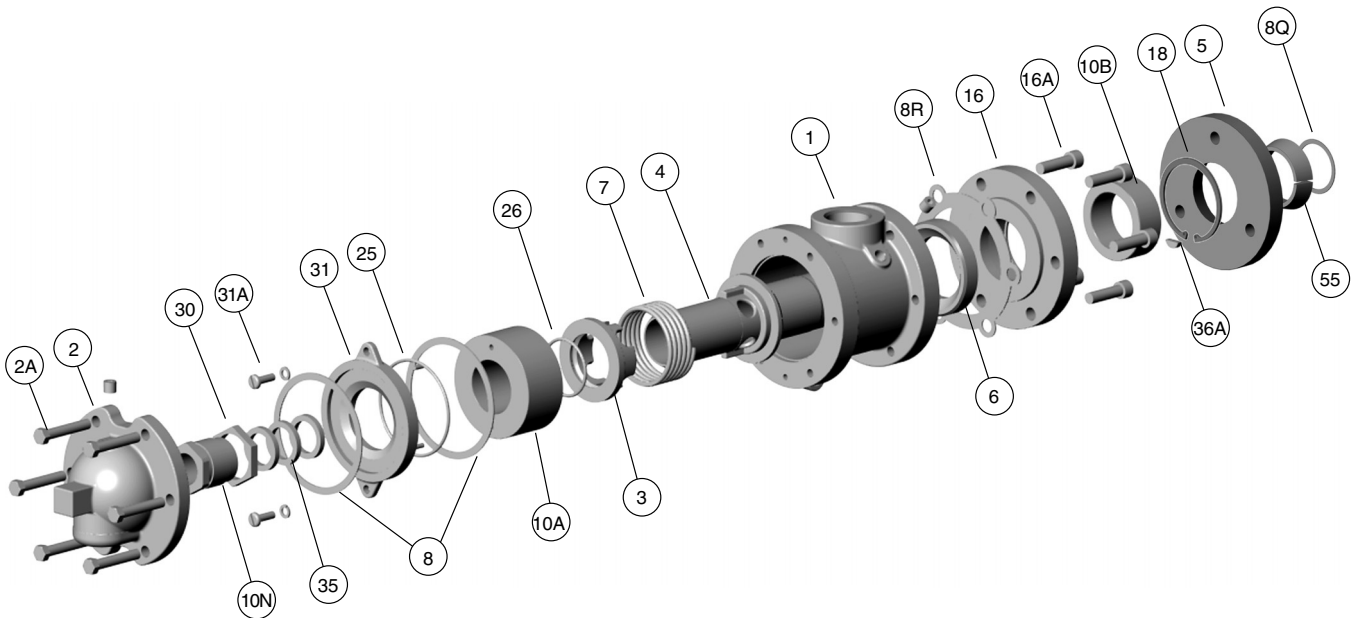

STEP 11.

Install a new back carbon guide (10B) into the wear plate (16) making sure the woodruff key slot faces toward the retainer ring groove. Position the woodruff key (36A) into it's slot. Install the retainer ring (18) into the groove to secure the back carbon guide. Make sure the retainer ring is positioned to hold (overlap) the woodruff key in the slot. Install the wear plate on to the body (1) using a new gasket (8R). Secure wear plate with hex head cap screws (16A) using a star pattern for a tightening sequence.

STEP 12.

Turn the rotary joint housing back upright and install a new carbon seal ring (6), flat side down, concave side facing outward. Caution: seal rings are hard but also brittle.

STEP 13.

Reinstall nipple (4) back into the body through the back guide, followed by the spring (7).

STEP 14.

Lubricate and install a new o-ring (26) into the groove on the spring shoulder (3). Align the key on the nipple (4) with the key way on the spring shoulder (3) and slide the spring shoulder onto the nipple.

STEP 15.

Set the front guide (10A) over the nipple next. The two pin holes should face outward.

STEP 16.

Place a new o-ring (25) into the groove on the face of assembly plate (31).

STEP 17.

Set gasket (8) on the end of the body.

STEP 18.

Aligning the two pins with the holes in the front guide and push down on the assembly plate and secure with the round head screws. Keys and keyways, pins and pin holes should align.

REINSTALLATION:

STEP 19.

Prior to installing the rotary joint on the machine place a new metal gasket (8Q) into the recess of the journal.

STEP 20.

Reinstall 'Q' nipple flange (5) over nipple (4).

STEP 21.

Into the recess of nipple (4) place the two tapered split wedges (55) and secure by sliding the 'Q' nipple flange back over the wedges.

STEP 22.

Slide the rotary joint over the center syphon pipe and engage 'Q' nipple flange (5) over the studs of the journal flange. Secure by evenly tightening the jam nuts.

Note that this flange will not fit tightly against the journal flange. There should be a space between both flanges. Make certain this gap is equal around the circumference of the flange.

STEP 23.

Insert two new packing rings into the packing gland.

STEP 24.

Tighten gland (10N) to approximately 40Nm. Lock down locknut (30). Reinstall head casting (2) with a new gasket (8). Reconnect the piping and joint will be ready for service.

Please refer to Kadant Johnson Drawing Number A37640 for recommended torque specifications.

The Kadant Johnson Warranty

Kadant Johnson products are built to a high standard of quality. Performance is what you desire: that is what we provide. Kadant Johnson products are warranted against defects in materials and workmanship for a period of one year after date of shipment. It is expressly understood and agreed that the limit of Kadant Johnson's liability shall, at Kadant Johnson's sole option, be the repair or resupply of a like quantity of non-defective product.

