

Installation Instructions for Type 9800 PTX Joints

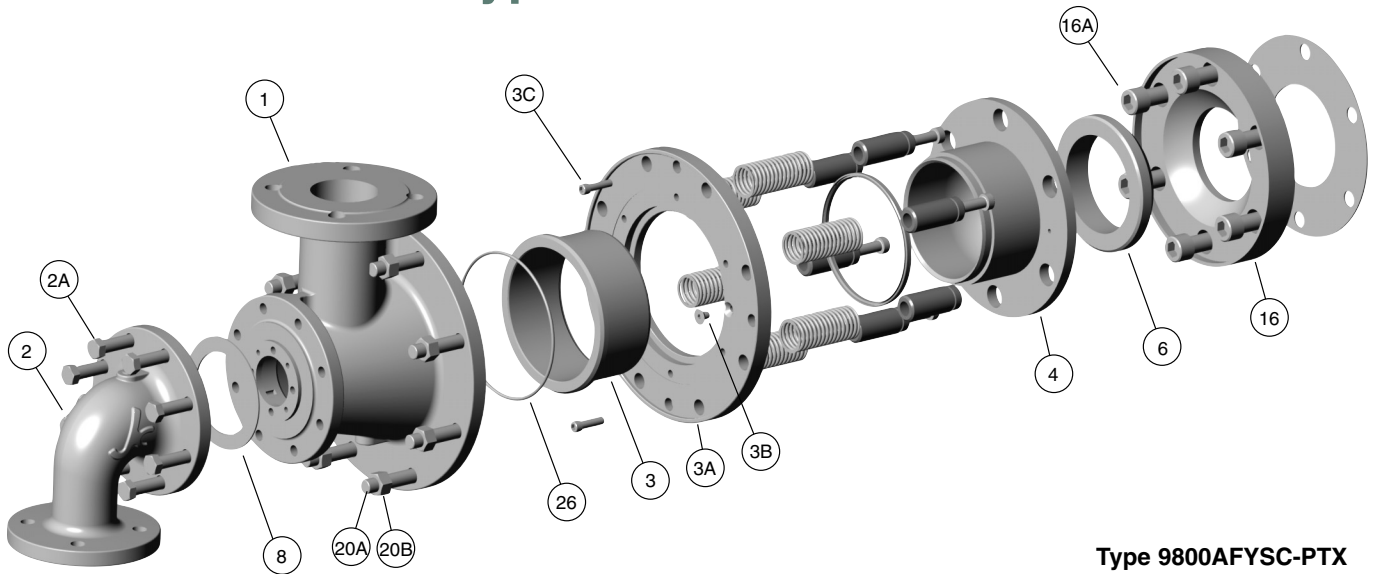

Type 9800AFYSC-PTX

NOTES: Please follow your company's safety procedures whenever working on Kadant Johnson Rotary Joints and read all of the instructions completely before proceeding.

Please refer to the assembly drawings supplied with your Kadant Johnson Rotary Joint for part identification.

The 9800 PTX Joint is shipped partially assembled. Disassemble joint, inventory and stage parts prior to installation.

STEP 1.

Remove all existing equipment down to a bare journal. Clean all gasket surfaces. Chase and clean all threaded holes. If necessary remove bearing cover. Note: Some installations may not require removing the bearing cover, please consult your factory representative if you have any questions.

STEP 2.

Various methods are incorporated to support the rotary joint. Most joints are supported by 1) a ring bracket, 2) a ring bracket and bearing cover supplied as one unit, 3) a ring bracket and bearing cover supplied as individual parts.

1. **With ring bracket only.** Install ring bracket (20). Secure into position using hex head cap screw (20C).

2. **With ring bracket and bearing cover as one unit.** Make sure the inside bearing area of the cover is clean and free of debris. Apply sealer to the appropriate area of the machine's bearing housing. Slide the bracket/bearing cover unit over the journal and secure into position with the proper size bolts.

3. **With ring bracket and bearing cover supplied as individual parts.** Make sure the bearing cover is clean and free of debris. Apply sealer to the appropriate area of the machine's bearing housing. Slide the bearing cover over the journal and secure into position with the proper size bolts. Install ring bracket (20) on to bearing cover and secure into position using hex head cap screw (20C).

STEP 3.

Place filler flange (5) and gasket (8B) on to journal. Secure into position using socket head cap screws (5A). Tighten flange screws evenly in a star pattern. In some cases it is necessary to install a second flange also. If required, do so in the above manner.

STEP 4.

Place wear plate (16) and gasket (8A) on to journal flange. Secure into position using socket head cap screws (16A). Tighten wear plate screws evenly in a star pattern.

STEP 5.

Clean the spherical face of the wear plate (16), the flat face of the nipple (4), and the mating surfaces of the seal ring (6). These sealing surfaces must be free of debris, oil or other contaminants. Place seal ring (6) with its spherical face into the mating surface of the wear plate (16). While holding the seal ring in position, install the end cap/nipple assembly (3, 3A, & 4) on to the ring bracket (20) and secure into position with four socket head cap screws (3C). As the socket head cap screws are tightened, spring force will be applied to the seal ring and the X dimension will be created. The X dimension is $13\text{mm} \pm 6\text{mm}$. When used with CARB bearings, the X dimension is $19\text{mm} \pm 6\text{mm}$. Make sure seal ring (6) is centered on the nipple (4). Please consult factory if the X dimension is incorrect or if the seal ring is not centered properly.

STEP 6.

There are two options for installing the cantilever support tube (H). In both options, the support tube must be installed so that the weld bead on the end of the support tube and indexing slot at the opposite end will be in the 12 o'clock position. The large hollow bolt (J) must be removed and the threads lubricated with never seize.

Option 1. If there is enough clearance between the dryer hood and the journal, you can install cantilever support tube (H) by inserting it through the partially assembled joint and down the journal bore. The plain end of the tube without the taper goes into the journal first. Leave the tapered end of the tube protruding out of the end cap approximately 180mm. Lubricate the o-ring (26) with silicone lubricant and place it into the face groove on the joint body (1). Apply never seize to the tapered portion on the cantilever support tube. Position the body over the cantilever support tube. Align the pins (10) in the body with the support tube indexing slots. Lift the body and support tube and position them over the studs (20A) on the ring bracket. Secure the body to the bracket with hex nuts (20B).

Option 2. Lubricate the o-ring (26) and place it into the o-ring groove on the joint body. Position the body over the studs (20A) on the ring bracket (20) and secure into position with nuts (20B). Apply never seize to the tapered portion on the cantilever support tube (H). From inside the dryer, insert the cantilever support tube, with the tapered end going in first, into the journal. Align the pins (10) in the body with the support tube indexing slots and push into position.

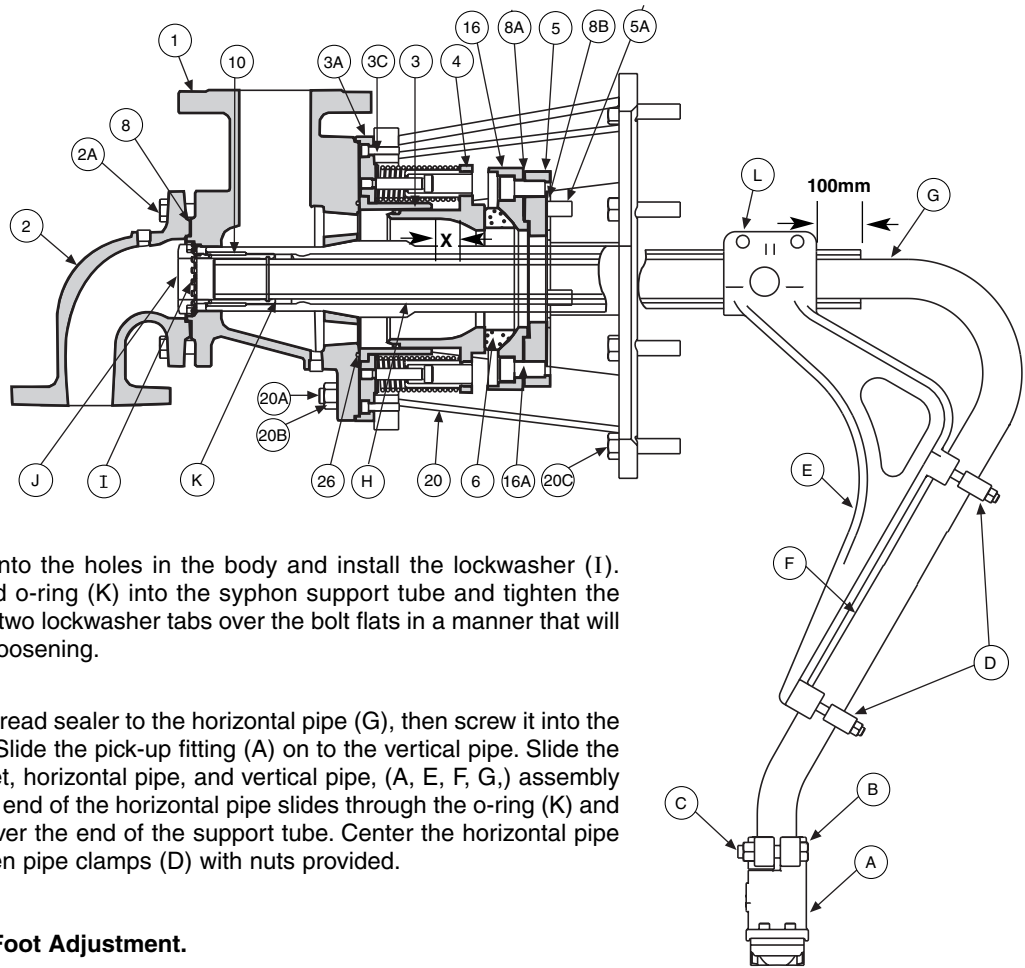

STEP 7.

Bend **two** lockwasher tabs into the holes in the body and install the lockwasher (I). Install the hollow bolt (J) and o-ring (K) into the syphon support tube and tighten the hollow bolt to 540 Nm. Bend two lockwasher tabs over the bolt flats in a manner that will prevent the hollow bolt from loosening.

STEP 8.

Inside the dryer, apply pipe thread sealer to the horizontal pipe (G), then screw it into the vertical pipe (F) and tighten. Slide the pick-up fitting (A) on to the vertical pipe. Slide the pick-up fitting, support bracket, horizontal pipe, and vertical pipe, (A, E, F, G,) assembly into the support tube until the end of the horizontal pipe slides through the o-ring (K) and the support bracket (E) fits over the end of the support tube. Center the horizontal pipe in the support tube and tighten pipe clamps (D) with nuts provided.

STEP 9.

Final Bracket and Pick-up Foot Adjustment.

Make sure the support bracket (E) is vertical and the syphon pick-up fitting (A) is at the bottom of the dryer. The pick-up fitting must be pointed into the rotation of the dryer for proper condensate evacuation. Adjust the circular portion of the support bracket so that it is 100mm back from the end of the support tube, or if the dryer has groove in the shell, center the pick-up foot in the dryer groove. Tighten support bracket clamp bolts (L) to 68 Nm. Set the pick-up fitting clearance by placing a gauge in the center of the pickup fitting (consult factory for clearance specification). Secure into final position by tightening bolt/nut (B & C). If the desired pick-up fitting clearance can not be obtained, please consult the factory.

STEP. 10

Check all counter weights and make sure they clear the syphon assembly as the dryer rotates. If necessary, the support bracket can be moved away from the dryer head up to 100mm by loosening support bracket clamp bolts and repositioning the bracket.

Check the cantilever support tube for clearance through the journal. The cantilever support tube must have at least 4,5mm clearance between its O.D. and the journal I.D.

STEP. 11

Place gasket (8) on to head (2). Install head on to body (1) and secure into position with head bolts (2A). The Kadant Johnson Rotary Joint is now ready to accept piping.

Dimensions are for reference only and subject to change. Certified drawings are available on request. Please refer to Kadant Johnson Drawing Number A37640 for torque specifications.

9800AFYSC – PTX

Pick-Up Fitting Orientation

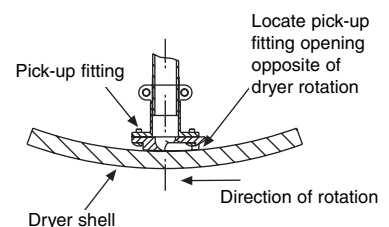

The Kadant Johnson Warranty

Kadant Johnson products are built to a high standard of quality. Performance is what you desire: that is what we provide. Kadant Johnson products are warranted against defects in materials and workmanship for a period of one year after date of shipment. It is expressly understood and agreed that the limit of Kadant Johnson's liability shall, at Kadant Johnson's sole option, be the repair or resupply of a like quantity of non-defective product.



www.kadantjohnson.com