

Installation Instructions for Type 5750SBAF Joints

FIGURE 1

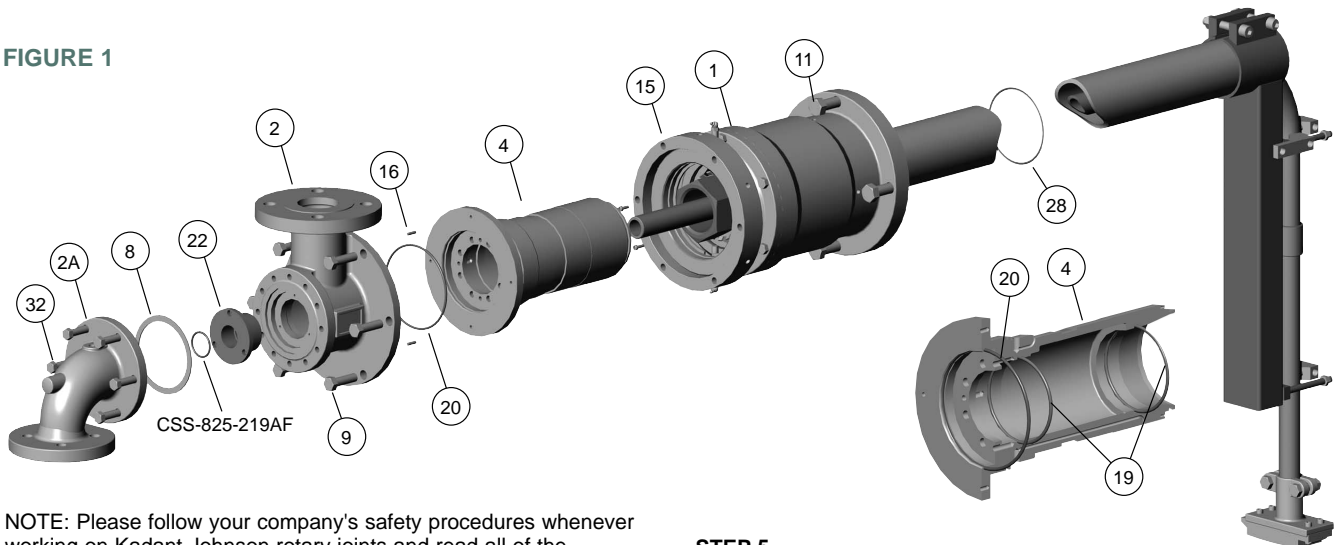

NOTE: Please follow your company's safety procedures whenever working on Kadant Johnson rotary joints and read all of the instructions completely before proceeding.

Please refer to the assembly drawings supplied with your Kadant Johnson rotary joint for part identification. If you have further questions, please contact Kadant Johnson.

ROTARY JOINT

STEP 1.

Inspect the journal gasket surface and remove all old gasket material and sealer from it. If old gasket material is left on the sealing surface, it may cause the new gasket to leak and it will cause excessive runout when the rotary joint is installed. Verify that the pilot on the journal flange (Figure 2, Item 5) will fit entirely into/over the journal and seat securely against the gasket (Figure 2, Item 7). The journal flange should not contact the drive gear or any other component on or near the journal except the gasket and the pilot surface.

STEP 2.

Install the journal flange and gasket. Tighten the socket head cap screws (Figure 2, Item 9) slightly more than finger tight.

STEP 3.

Install the expanding mandrel for the dial indicator into the bore on the journal flange and adjust the dial indicator to read on the outside diameter of the dryer journal. Be sure to place the dial indicator on a clean, well-machined surface such as the surface that the gear is mounted to. Remove any dirt and rust from the surface where the gauge is reading.

STEP 4.

Swing the dial indicator around its pivot and determine how much travel the indicator makes. Tap the journal flange lightly with a lead hammer where the indicator shows the high point and then rotate the dial indicator again. Repeat this process until the dial indicator shows less than 0,25 mm of runout for the full circumference of the journal. Tighten the socket head cap screws to the specified torque in Table 1 and then verify that the runout is less than 0,25 mm.

STEP 5.

Install the o-ring (Figure 2, Item 11) in the groove on the filler flange (Figure 2, Item 6). Lubricate o-ring with a non-petroleum based o-ring lubricant. Do not use Vaseline, Never Seize, grease or lubricating oil as an o-ring lubricant. Fasten filler flange with o-ring in place to journal flange and tighten the socket head cap screws (Figure 2, Item 10) according to the specifications listed in Table 1.

STEP 6.

Remove the elbow (Figure 1, Item 2A) and head (Figure 1, Item 2) from the rotary joint. They are shipped with the fasteners finger tight to allow quick disassembly. Install the o-ring (Figure 1, Item 28) on the joint pilot (which protrudes from the assembly plate) if it is not already in place and lubricate it.

STEP 7.

Install the two support tube o-rings (Figure 1, Item 19) inside the joint nipple (Figure 1, Item 4). See the illustration for the location of these o-rings. Lubricate the surface of the o-rings after they are installed.

STEP 8.

Align the joint pilot with the counter bore in the filler flange and carefully push the joint into the flange. Do not push the pilot into the flange at an angle as this may cause o-ring damage and result in a leak when the joint is in operation. Rotate the joint in the flange until the clearance holes in the body flange line-up with the threaded holes in the filler flange.

STEP 9.

Install the hex head cap screws (Figure 1, Item 11) through the flange on the joint body (Figure 1, Item 1) and into the filler flange. They are 5/8" fasteners and they should be tightened according to the specifications listed in Table 1.

STEP 10.

Install the larger expandable arbor into the end of the nipple and adjust the dial indicator to rest on the same surface used to align

FIGURE 2

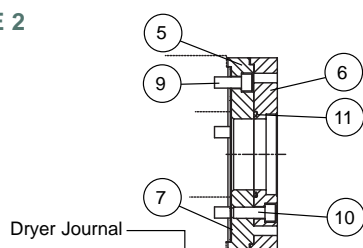

Journal Flange and Filler Flange Assembly

FIGURE 3

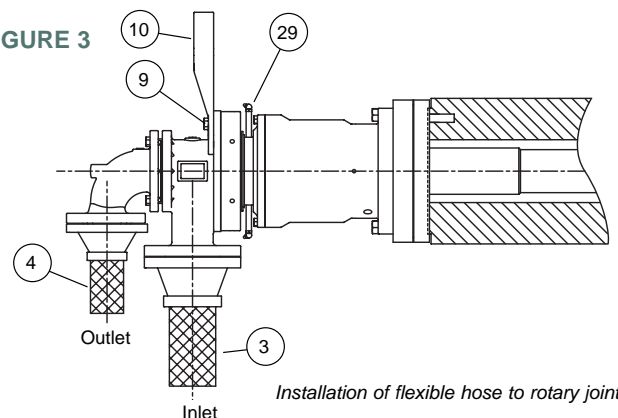

Installation of flexible hose to rotary joint

the journal flange. Rotate the dial indicator and check the runout. Install shims between the body flange and the filler flange as needed to achieve 0,5 mm of total runout. Verify that all of the bolts will pull tightly against the filler flange or shims. If several shims are installed at one bolt location, a shim may be required at the two bolts nearest to it to eliminate the clearance created between the joint flange and filler flange.

SYPHON

STEP 11.

Rotate the rotary joint nipple until the grease fittings (Figure 3, Item 29) are either horizontal or vertical, whichever is preferred for the final installation. The syphon support tube (Figure 4, Item 12) will be installed next. Lubricate syphon support tube where shown with Never Seize. Working inside the dryer, assemble the bracket on the vertical support (Figure 4, Item 1) onto the support tube as shown in the illustration with the threaded bosses facing away from the dryer head. Align the slot in the end of the support tube with the slot in the vertical support. The support tube extends 6 mm past the end of the vertical support bracket when it is correctly positioned. Remove the protective plastic mesh from the end of the support tube and carefully guide it through the journal into the rotary joint. Push the support tube past the first o-ring inside the rotary joint nipple and then hold it in place. The person outside the dryer rotates the nipple until the four torque pins inside the nipple are aligned with the grooves in the end of the support tube. Verify that the grease fittings are oriented in the desired direction when the vertical support is in the 6 o'clock position inside the dryer before proceeding.

STEP 12.

Apply a thin film of thread lubricant such as Never Seize on the threads of the large hollow bolt (Figure 4, Item 17). Place the lock washer (Figure 4, Item 18) over the hole in the center of the rotary joint nipple with the single bent tab protruding into one of the eight 3/8" holes and install the large hollow bolt. Tighten the bolt to 170 NM. Bend one of the tabs on the lock washer until it rests securely against the hex portion of the syphon fastener. Verify that the tab is bent against the correct side of the hex to prevent rotation in the counter clockwise direction. If the tab is bent in the wrong location, it will allow the fastener to rotate before it hits the tab.

STEP 13.

Working inside the dryer, install the vertical leg (Figure 4, Item 6A) on the horizontal pipe (Figure 4, Item 6) and tighten it securely. Pipe thread compound is recommended on these threads.

STEP 14.

Slide the pick-up fitting (Figure 4, Item 11) onto the vertical leg and finger tighten the screws that clamp it in place. Remove the lock nuts (Figure 4, Item 15) on the vertical support bracket pipe clamps (Figure 4, Item 10) and remove the outermost portion of the clamp.

STEP 15.

Insert the horizontal pipe into the support tube until the vertical leg touches the "V" shaped notches in the pipe clamps on the vertical support bracket. Install the outer portion of the pipe clamps and tighten them in place while keeping the horizontal pipe centered in the support tube. Tighten the pipe clamp nuts evenly to avoid bending the studs.

STEP 16.

Verify that the o-ring (CSS-825-219AF) is in place in the pipe gland (Figure 1, Item 22) in the head and lubricate the surface with a non-petroleum based o-ring lubricant. Lubricate and verify that the o-ring (Figure 1, Item 20) is in place in the o-ring groove

FASTENER SIZE	TORQUE VALUE (NM)
7/16"	55
1/2"	80
9/16"	120
5/8"	160
3/4"	270

Table 1

in the end of the nipple (Figure 1, Item 4). Place the rotary joint head over the horizontal pipe and align the shear pins (Figure 1, Item 16) protruding from the nipple with the holes in the head. The head can be oriented such that the pipe connection can be in the 12, 3, 6 or 9 o'clock position. Fasten the head to the nipple retaining plate (Figure 1, Item 15) using the six 1/2" hex head cap screws (Figure 1, Item 9) that are provided. Do not tighten them at this time.

ADJUSTMENTS

STEP 17.

Verify that the syphon pickup fitting is located in the proper position inside the dryer. The pick-up fitting must be pointed into the rotation of the dryer for proper condensate evacuation. Adjust the location of the vertical support bracket on the support tube if necessary. Do not move the vertical support bracket past the point that the support tube is flush with the end of it.

STEP 18.

Loosen the screws on the pick-up fitting and slide it on the vertical leg until the minimum clearance between the dryer surface and the shoe is at the minimum clearance as specified by Kadant Johnson. Tighten the fasteners lightly and rotate the entire syphon assembly inside the dryer. Check the clearance between the dryer shell and the pick up fitting all the way around. Readjust the pickup fitting location until the minimum clearance is achieved all of the way around the dryer. When this is achieved, tighten screws that hold the pick-up fitting securely and tighten the jam nuts against the boss on the pick-up fitting. The syphon installation is now completed.

STEP 19.

Install the torque lug (Figure 3, Item 10) such that the tab on it rests in a in a slotted bracket (supplied by the mill unless special ordered from Kadant Johnson Inc.). The slot must allow the tab on the torque lug to move axially with the dryer to allow for thermal expansion. The torque lug should fit into the slot with approximately 3 mm of clearance side to side. Several longer hex head cap screws (Figure 3, Item 9) are provided for use with the torque bracket. The frame that the "U" shaped bracket is attached to must be rigid. This will prevent the rotary joint head and syphon from turning while the system is in operation. Tighten the six 1/2" screws that fasten the head and torque lug to the rotary joint according to Table 1.

STEP 20.

Place the gasket (Figure 1, Item 8) over the pilot on the elbow and fasten it to the rotary joint head using the six 7/16" hex head cap screws (Figure 1, Item 32) provided. Tighten the screws according to Table 1. The elbow must be pointed down or to the side to allow efficient dryer evacuation. Do not mount the elbow pointing up.

STEP 21.

Install the flexible hoses (Figure 3, Items 3 & 4) to the rotary joint according to Kadant Johnson drawing number A-97-1615-3-1.

Dimensions are for reference only and subject to change. Certified drawings are available on request. Please refer to Kadant Johnson Drawing Number A37640 for torque specifications.

FIGURE 4

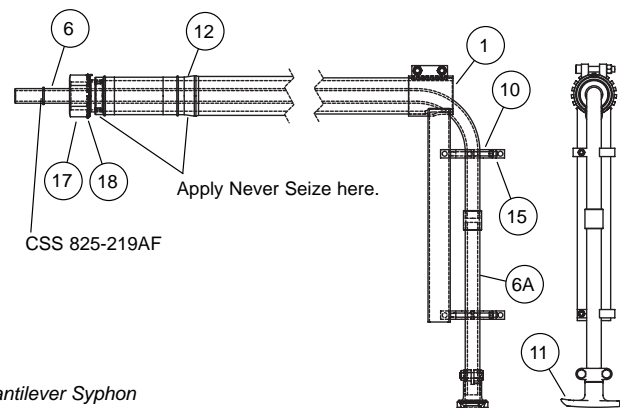

Cantilever Syphon

The Kadant Johnson Warranty

Kadant Johnson products are built to a high standard of quality. Performance is what you desire: that is what we provide. Kadant Johnson products are warranted against defects in materials and workmanship for a period of one year after date of shipment. It is expressly understood and agreed that the limit of Kadant Johnson's liability shall, at Kadant Johnson's sole option, be the repair or resupply of a like quantity of non-defective product.

