

# Installation Instructions for Type PT Joints – 2000 Series

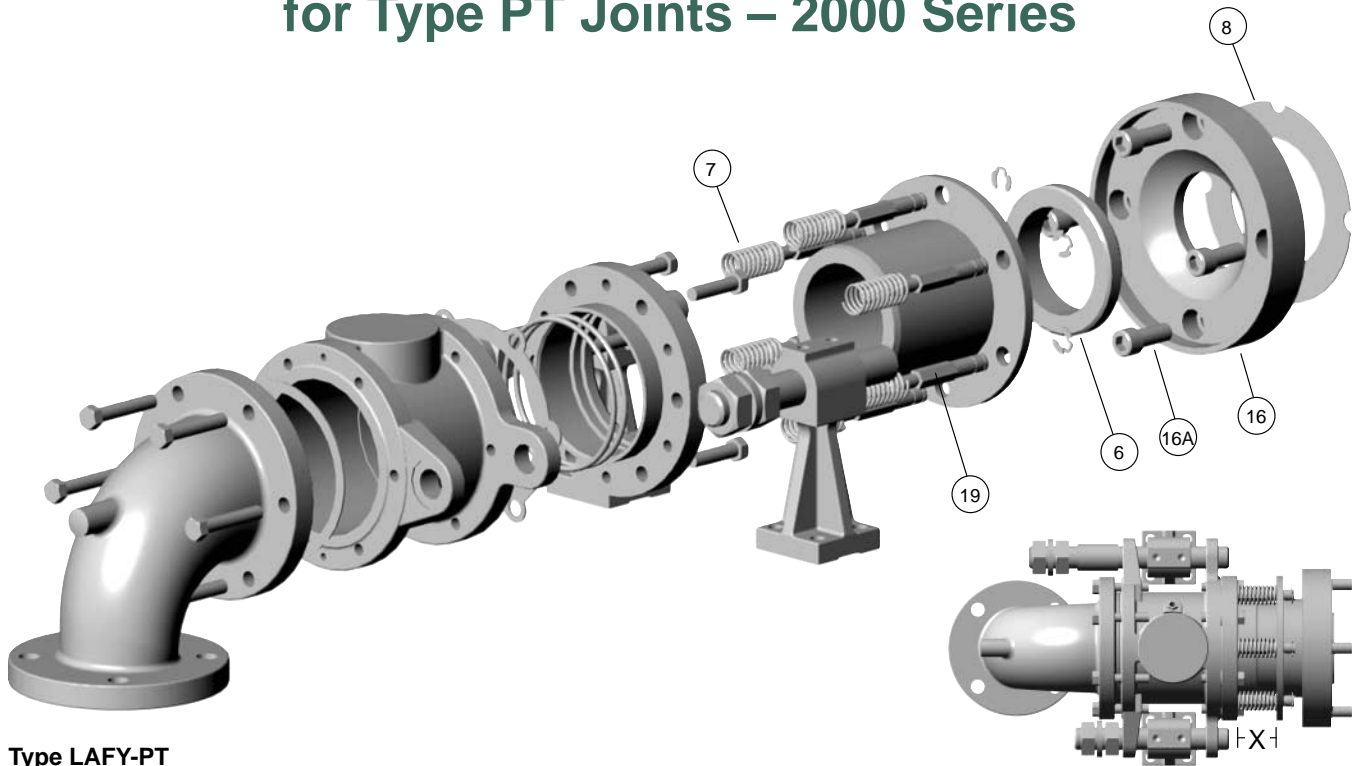

Type LAFY-PT

## STEP 1.

Check to make sure all dryer gasket surfaces and tapped holes are clean and free of all foreign debris before commencing the installation. Re-tap all threaded holes in order to obtain proper thread engagement.

## STEP 2.

Using the bolts and gasket provided, fasten filler flange to the end of the journal (if applicable).

## STEP 3.

Attach wear plate (16) to the face of the filler flange, using bolts (16A) and gasket (8) provided.

## STEP 4.

There are two ways to preload the joint springs (7). **If the joint is equipped with two threaded pins**, turn the hex jam nuts inward until dimension (X) equals “set-up” dimension listed on blueprint. (If blueprint is unavailable, contact factory for proper dimension.)

**If the joint does not have threaded pins**, spring tension will take place during joint mounting.

## STEP 5.

**If the joint has had springs compressed as in Step 4.**

Position a new carbon seal ring (6) in the recessed area of the wear plate (16). Slide the joint over the support rods through the holes in the body lugs. Push the joint toward the

roll until it is in firm contact with the carbon seal ring. Install the support rod nuts onto the support rods. Continue to run the support rod nuts down the support rods until they contacted the joint support lug. Make sure the joint is on center and perpendicular to the roll centerline. Run a second nut down the support rod and jam it against the first nut. Remove the nuts that were installed in Step 4.

**If the joint springs have not been pre-compressed as in Step 4.** Position a new carbon seal ring (6) in the recessed area of the wear plate (16). Slide the joint over the support rods through the holes in the body lugs. Push the joint toward the roll until it is in firm contact with the carbon seal ring. Using the support rod nuts, continue to move the joint towards the roll, until the correct (X) dimension is obtained. Make sure the joint is on center and perpendicular to the roll centerline. Run a second nut down the support rod and jam it against the first nut.

## STEP 6.

Attach piping to the joint head. The installation is now complete. As the carbon seal ring wears, the springs will extend, and dimension (X) will increase. If left unattended, the nipple flange will ultimately contact the retainer rings on the spring pins (19), causing the joint to leak. To prevent leakage, seal rings should be replaced when dimension (X) reaches “worn” dimension listed on blueprint. Seal ring replacement should follow procedures in Kadant Johnson Repair Bulletins.

### The Kadant Johnson Warranty

Kadant Johnson products are built to a high standard of quality. Performance is what you desire: that is what we provide. Kadant Johnson products are warranted against defects in materials and workmanship for a period of one year after date of shipment. It is expressly understood and agreed that the limit of Kadant Johnson's liability shall, at Kadant Johnson's sole option, be the repair or resupply of a like quantity of non-defective product.