

Installation Instructions for Type RX Joints (4" – 6")

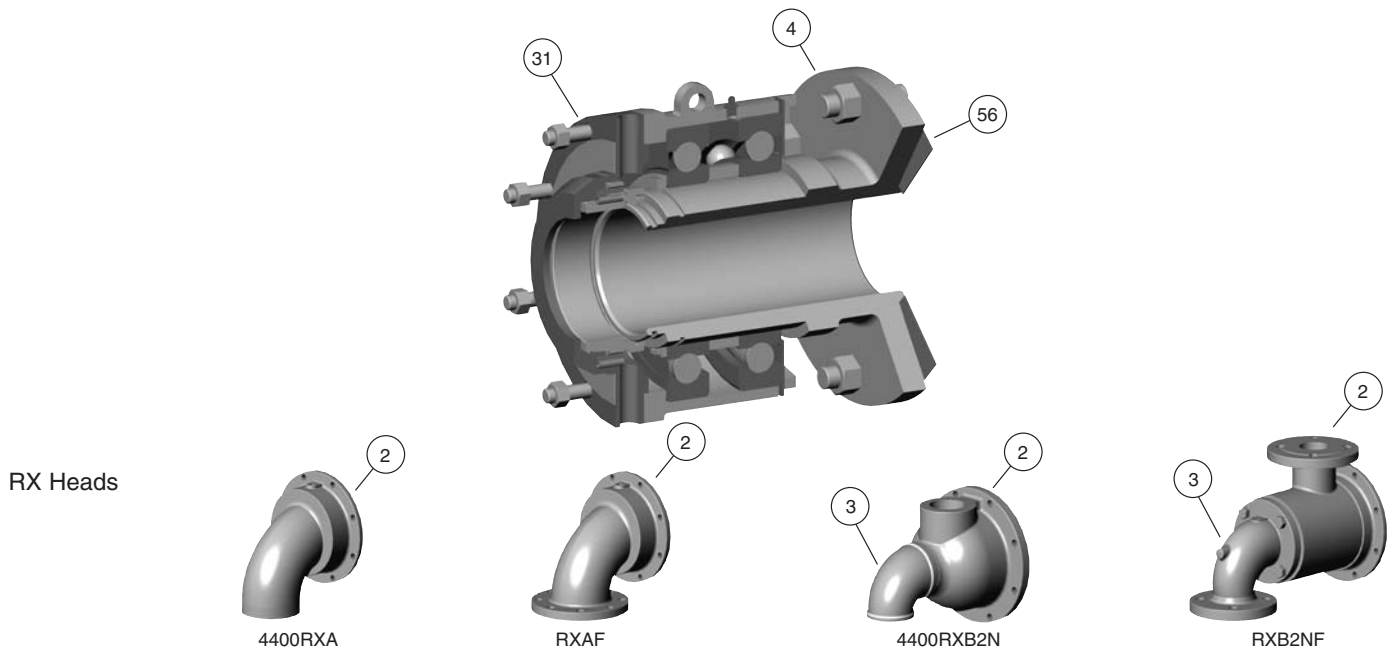

RX Heads

NOTE: Please follow your company's safety procedures whenever working on Kadant Johnson rotary joints and read all of the instructions completely before proceeding.

Please refer to the assembly drawings supplied with your Kadant Johnson rotary joint for part identification. If you have any further questions, please contact your Representative or Kadant Johnson.

MOUNTING TO JOURNAL

The RX joint is designed with an integral flanged nipple. This configuration minimizes the potential misalignment that can take place between the nipple and the roll end.

Prior to mounting the joint to the roll end, care should be taken to ensure that both mating faces are clean and free of burrs. A lifting mechanism such as a crane or hoist may be used to support the weight of the joint during installation. The RX joint can also be installed with the head (2) removed, decreasing the weight and allowing easier handling.

SINGLE FLOW - NO HORIZONTAL PIPE

RXA - Threaded Elbow Connection

RXAF - Flanged Elbow Connection

Attach in manner described under "Mounting Instructions".

DUAL FLOW - ROTARY HORIZONTAL PIPE

RXB2N - Threaded Connections

RXB2NF - Flanged Connections

While holding the joint straight, slide the assembly slowly over the horizontal pipe, allowing the pipe to fit into the head bushing.

Then attach to journal as described under "Mounting Instructions".

MOUNTING INSTRUCTIONS

Place the nipple gasket (56) on the nipple flange (4) by fitting it over the pilot. Then slip the pilot of the nipple flange into the counterbore in the roll end. Attach with the appropriate fasteners for the application. Tighten fasteners evenly to the proper torque, in order to seal flange surfaces and minimize runout.

Pay special attention to concentricity. At high RPM's the bearings will yield longer, trouble-free service life if runout is kept to a minimum. See Table 1 for speed and maximum recommended runout allowance. Runout can be checked on the nipple flange or the OD of the assembly plate with a dial indicator while rotating the roll.

INSTALLATION NOTES – DUAL FLOW APPLICATIONS

1. Take special care when mounting the joint over the horizontal pipe as internal seals can be damaged.
2. The horizontal pipe can be guided to the head bushing while looking through the head connection.
3. Attention should be given to length of horizontal pipe. Excess length can cause flow to be cut off against interior of the elbow.

Joint Version	Maximum Speed	Maximum Runout
Standard Water	750 RPM	0.012" (0.304 mm)
-1 High End Water	750 RPM	0.012" (0.304 mm)
-2 Standard Oil	750 RPM	0.012" (0.304 mm)
-3 High End Oil	750 RPM	0.012" (0.304 mm)

Table 1

FLEXIBLE HOSE CONNECTION

Given your application, choose either rubber or metal braided hose with ratings able to sustain the flow media. When connecting the rotary joint to the fixed piping, the flexible hose should be installed as close to the joint as possible, in a relaxed condition, neither stretched or compressed. If you have an unusually long run of hose, it is strongly recommended that you support the hose so as not to overload the bearings. Refer to Table 2 to determine the correct length of flexible hose needed to isolate the Johnson joint from piping stresses.

WEEP HOLES

1. There are two weep holes in the assembly plate (31) of the rotary joint. They provide an escape for leakage at the internal seals, which indicate the need for seal replacement, and also prevent liquid penetration of the bearings.
2. The rotary joint should be oriented such that one of the weep holes is pointing directly downward during operation. The head (2) and elbow (3) can be unbolted and repositioned as required to allow for proper location of the weep hole.
3. The weep holes are threaded 1/2" NPT to allow for connection of a drain line. This is recommended on higher temperature liquid service to direct any leakage away from personnel areas.

Recommended Minimum Hose Lengths For Braided Stainless Steel Flexible Hose				
Pipe Size	Minimum Length	Static Bend	Intermittent Bend	Maximum Offset
2	21	5.00	15	2-1/8
2-1/2	22	7.00	14	2-7/16
3	24	8.25	17	2-9/16
4	28	11.00	22	2-15/16
5	30	11.00	28	2-1/2
6	33	16.50	33	2-5/8

Table 2

ANTI-ROTATION DEVICE

Depending on the joint configuration, your RX joint is furnished with one of two types of anti-rotation devices. These devices serve the purpose of holding the joint body stationary while the roll is turning. Without an anti-rotation device the torque applied by the rotation of the joint would pull and strain the flexible hose connecting the joint to the piping. This loading could cause premature hose failure.

RX WITH BALL BEARINGS - FIGURE A

This version of the joint comes with a lug on the body for attaching an anti-rotation rod. Use plain or threaded 1/2" carbon steel rod slipped through the anti-rotation lug in the body and affixed to a stationary bracket or framework. If two 4400RX joints are installed side-by-side, they can use a common anti-rotation rod.

RX WITH TAPERED ROLLER BEARINGS - FIGURE B

This version of the joint comes with a torque lug bracket bolted to the body. This bracket should be oriented on installation to come in contact with a stationary bracket or framework. While the joint rotates the anti-torque lug bracket will rest against the stationary frame or bracket preventing the joint body from rotating.

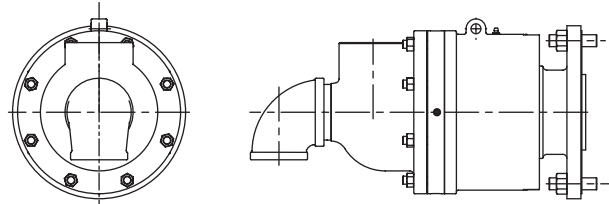

Figure A

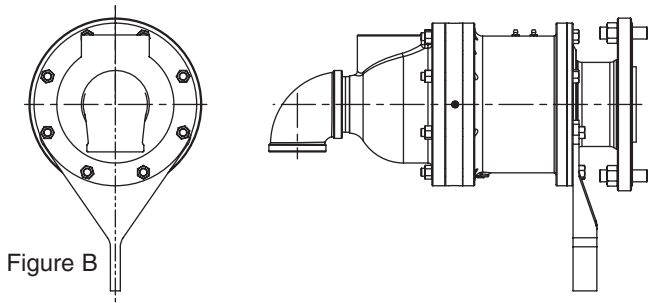

Figure B

The Kadant Johnson Warranty

Kadant Johnson products are built to a high standard of quality. Performance is what you desire: that is what we provide. Kadant Johnson products are warranted against defects in materials and workmanship for a period of one year after date of shipment. It is expressly understood and agreed that the limit of Kadant Johnson's liability shall, at Kadant Johnson's sole option, be the repair or resupply of a like quantity of non-defective product.

KADANT
AN ACCENT ON INNOVATION
www.kadant.com