

Installation Instructions for CorrPro™ Joint and Stationary Syphon

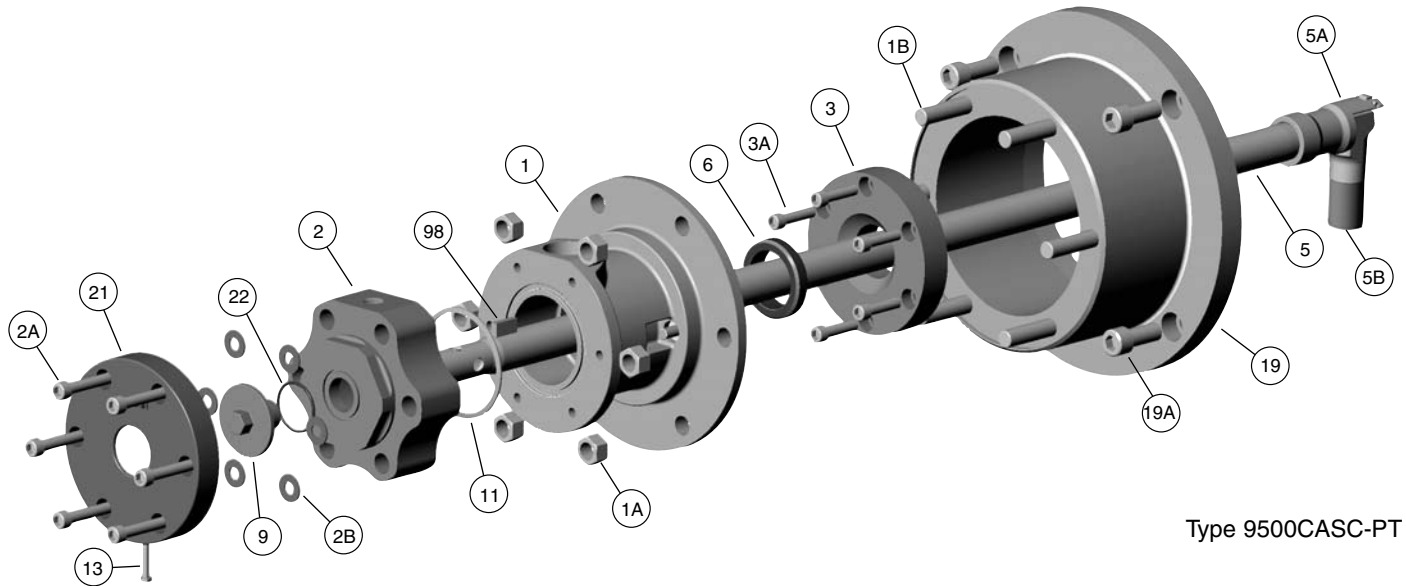

Type 9500CASC-PT

Please follow your company's safety procedures whenever working on Kadant Johnson rotary joints. Read all of the instructions completely before proceeding.

Please refer to the assembly drawings supplied with your Kadant Johnson rotary joint for part identification. If you have any questions, contact your Representative or Kadant Johnson.

NOTE: Do not use anti-seize or petroleum-based products on o-rings. Only lubricate the o-rings with the silicone lubricant supplied with the Kadant Johnson repair kit. Prior to handling lubricants, consult MSDS information.

PREPARE FOR INSTALLATION

Remove existing internal and external equipment, including the joint, lug supports, syphon, journal adapter flanges, etc. The roll should be stripped down to the journal. If a new bearing cover is included with the CorrPro Joint, remove the existing cover at this time. Save any equipment that is to be reused.

Clean the journal face of all debris. If the new wear plate (3) uses an o-ring to seal on the ID of the journal bore, clean the journal bore surface. Make sure there is a lead-in chamfer in the end of the journal bore, allowing the o-ring to compress and not get damaged during installation. Clean the area where the bracket (19) mounts to the machine of all debris that may prevent it from mounting firmly to the machine.

Clean all tapped holes using a bottoming tap.

STEP 1.

If applicable, install the journal adapter flange to the journal using the appropriate gasket or o-ring(s) as shown on the assembly drawing for the installation. If o-rings are used, apply a film of Parker® O-ring Lube before installation. Tighten the fasteners evenly in a star pattern using the proper torque.

Install the applicable o-rings or gasket to the wear plate. If o-rings are used, apply a film of Parker® O-ring Lube before installation. Place wear plate (3) onto the journal. Install the wear

plate fasteners (3A) and tighten evenly in a star pattern using the proper torque.

STEP 2.

There are two styles of brackets that may be used. One style is integrated into the bearing cover; the other is mounted to the machine face. Install the mounting bracket (19) to the machine using the appropriate fasteners (19A) and secure evenly. If an integrated bearing cover/bracket is used, follow the machine manufacturer's recommendations for installation.

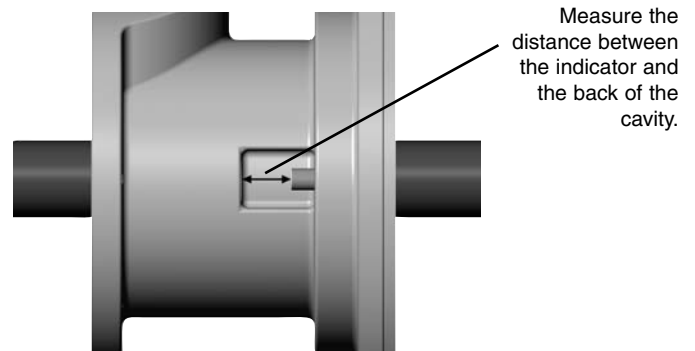

Figure 1. Initial seal ring indicator measurement

STEP 3.

Before installing the joint body (1), an initial measurement needs to be taken from the seal ring wear indicator as show in Figure 1. This can be done using snap gauges and calipers. Record this measurement for later use.

Place three drops of seal ring installation fluid (supplied) equally spaced on the conical side of the seal ring (6). Place the seal ring onto the wear plate (3), making sure that it is centered. The seal ring should stick to the wear plate. **CAUTION:** Take care that the seal ring does not fall from the wear plate.

Place the body assembly (1) up to the bracket (19), making sure that the piston inside of the body lines up with the flat

face of the seal ring. Line up the holes in the body with the bracket, making sure that the inlet connection is in the desired orientation. Fasten the body to the bracket using the supplied fasteners (1A). Please note that the fasteners may be nuts or bolts depending on the installation. Tighten the fasteners evenly in a star pattern using the proper torque.

STEP 4.

With the joint body installed, re-measure the seal ring wear indicator as in Step 3. Subtract the measurement taken in Step 3 from this number. This number should be between 0.225" (6 mm) and 0.350" (9 mm). This is the amount of seal ring wear that is available at room temperature. Record this number.

STEP 5.

Pre-Installation Checks:

1) The horizontal pipe (5) and vertical pipe (5B) in most cases are preassembled from the factory. If they are not, install them into the elbow (5A) at this time. Make sure that the locking insert and spring are inserted into the elbow before installing the horizontal pipe. Use Loctite® 272 on the threaded connections.

2) Make sure that the elbow (5A), when in the locked position, is 180° from the key (98) located on the opposite end of the horizontal pipe (5).

3) Check the vertical pipe (5B) length by measuring from the bottom of the vertical pipe to the bottom of the elbow. Add the following to this dimension:

1.93" (49 mm) – this is the elbow centerline dimension.

The desired shell to syphon clearance is recommended to be set at 3/8" (10 mm) to start.

The adjustment for syphon deflection is approximately 3/16" (5 mm).

The sum of these dimensions should equal the radius of the roll.

With the syphon in the open position, apply Loctite® 242 to the threaded insert.

While still in the open position, slide the syphon assembly through the journal of the roll. Gently rotate it so that the vertical leg is in the six-o'clock position after sliding through the journal.

Insert the locking tool through the horizontal pipe until it contacts the insert. Turn the tool clockwise until you feel it engage the locking insert key. Turn the tool clockwise two more times to ensure engagement. While pushing on the tool, rotate it counterclockwise until the "T", which is stamped on the tool, is facing up. Now pull the tool back. You should feel it come back approximately 1" (25 mm). Push the tool forward and start to turn the tool clockwise. The insert should now be threading into the vertical leg. Tighten the insert to 50 ft-lbs (68 Nm).

STEP 6.

Apply never seize to the tapered portion of the syphon pipe (5). Make sure that the energized seal (11) is installed in the groove on the body (1). Apply a thin film of o-ring lubricant on the energized seal. Apply a thin film of o-ring lubricant and install the cup seal (22) into the groove in the head (2).

Orient the outlet connection in the desired position and slide the head (2) over the syphon pipe (5), making sure that the key (98) on the pipe engages the groove in the head.

Apply never seize compound to the support tube nut (9) threads and install into the end of the syphon. Do not fully tighten the nut at this time.

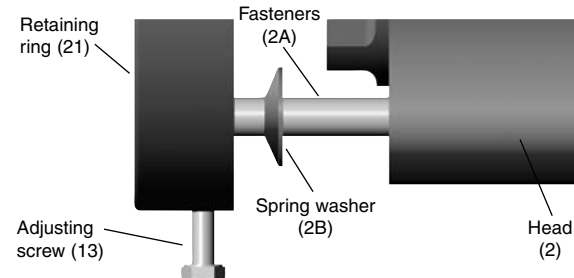

Figure 2

STEP 7.

Slide the fasteners (2A) into the retaining ring (21). Slide the spring washers (2B) over the fasteners (2A). Make sure that the washer is installed with the cone facing the retaining ring as shown in Figure 2.

Turn the adjusting screw (13) so that it is below the ID of the retaining ring (21). Slide the retaining ring with fasteners and spring washers (2A and 2B) into the head (2) and fasten to the joint body (1). Make sure that the head is in the lowest position by pushing down on the head with the fasteners loose and the adjusting screw (13) in its lowest position. Tighten the fasteners in a star pattern to 30 to 42 ft-lbs (41 to 57 Nm).

STEP 8.

If possible, rotate the roll by hand and listen for the syphon rubbing against the ID of the roll. If the syphon is rubbing, then remove the syphon and cut approximately 1/8" (3 mm) from the bottom of the vertical pipe (5B). Reinstall and check again. Repeat this process as necessary. After final adjustment is made, reapply Loctite® 242 to the threaded insert. The syphon should now be approximately 1/16" (1.5 mm) to 1/8" (3 mm) from the shell. Loosen the head fasteners (2A) approximately one turn. With the head (2) loose, the adjusting screw (13) can now be turned clockwise which will adjust the syphon up. Turn the adjusting screw to its maximum position. This will give you a minimum shell to syphon clearance of 1/4" (6 mm). Tighten the head fasteners evenly. Tighten the support tube nut (9) to 175 to 200 ft-lbs (237 to 271 Nm).

The joint is ready for the flexible hose piping.

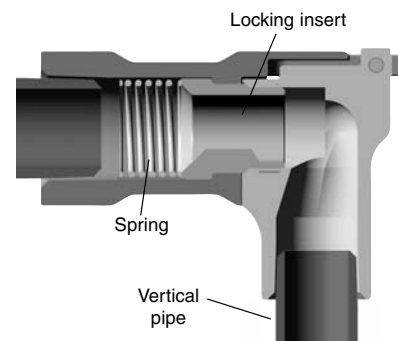

Syphon Elbow

Specifications and dimensions are for reference only and subject to change. Certified drawings are available on request.

The Kadant Johnson Warranty

Kadant Johnson products are built to a high standard of quality. Performance is what you desire: that is what we provide. Kadant Johnson products are warranted against defects in materials and workmanship for a period of one year after date of shipment. It is expressly understood and agreed that the limit of Kadant Johnson's liability shall, at Kadant Johnson's sole option, be the repair or resupply of a like quantity of non-defective product.

KADANT
AN ACCENT ON INNOVATION
www.kadant.com