

Installation Instructions for Type 9800 PT Joints with Cantilever Syphon

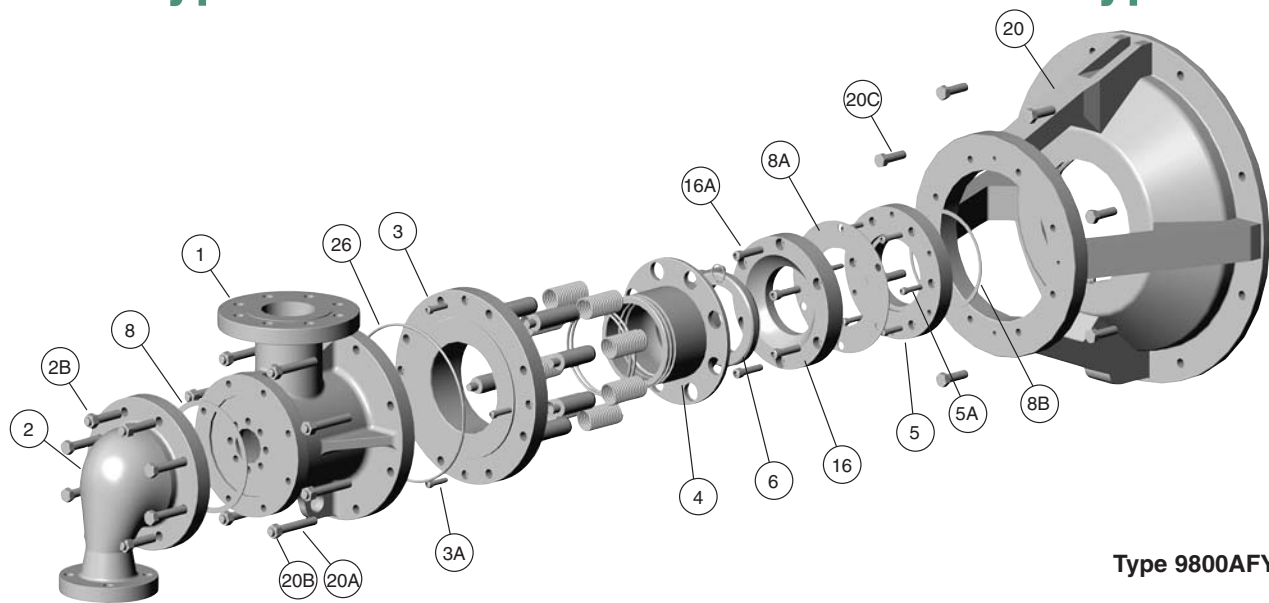

Type 9800AFYSC-PT

Follow your company's safety procedures whenever working on Kadant Johnson products. Read all of the instructions before proceeding with installation or repair.

Please refer to the Kadant Johnson assembly drawing for part identification. Assembly drawings are available on request from Kadant Johnson.

Lubricate all fasteners with anti-seize compound. Tighten all fasteners in a star pattern. Torque specifications are listed on the product assembly drawing and are available from Kadant Johnson.

The Kadant Johnson rotary joint is shipped partially assembled. Disassemble joint, inventory and stage parts prior to installation day.

STEP 1.

Remove all existing equipment down to a bare journal. Clean all gasket surfaces. Chase and clean all threaded holes. If necessary, remove bearing cover. Note: Some installations may not require removing the bearing cover, please consult Kadant Johnson if you have any questions.

STEP 2. (See Figure 1)

The joints are supported by a ring bracket or a ring bracket and bearing cover supplied as individual parts.

1. With ring bracket only. Perform Step 3 first. Then install ring bracket (20). Secure into position using hex head cap screws (20C).

2. With ring bracket and bearing cover supplied as individual parts. Make sure the bearing cover is clean and free of debris. Apply sealer to the appropriate area of the machine's bearing housing. Slide the bearing cover over the journal and secure into position with the proper size bolts. Then perform Step 3. Install ring bracket (20) onto bearing cover and secure into position using hex head cap screws (20C).

STEP 3.

If an insulating sleeve is required, install it during this step following the instructions that came with the insulating sleeve.

STEP 4.

Place journal flange (5) and gasket (8B) onto journal. Secure into position using socket head cap screws (5A). Tighten flange

screws evenly in a star pattern. In some cases it is necessary to install a filler flange also. If required, do so in the above manner.

STEP 5.

Place wear plate (16) and gasket (8A) onto journal flange. Secure into position using socket head cap screws (16A). Tighten wear plate screws evenly in a star pattern.

STEP 6.

Place seal ring (6) with its spherical face into the mating surface of the wear plate (16). While holding the seal ring in position, install the end cap/nipple assembly (3, 4) onto the ring bracket (20) and secure into position with four socket head cap screws (3A). As the socket head cap screws are tightened, spring force will be applied to the seal ring and the X dimension will be created. The X dimension is $9/16" \pm .150"$ ($11 \text{ mm} \pm 4 \text{ mm}$). Make sure seal ring (6) is centered on the nipple (4). Please contact Kadant Johnson if the X dimension is incorrect or if the seal ring is not centered properly.

STEP 7.

There are two options for installing the cantilever support tube (I).

Before you begin and if required, install the drive lock pin into the hole predrilled in the tapered end of the cantilever support tube, opposite the pin that is factory installed.

Apply Never Seize lubricant to the tapered portion of the support tube.

Option 1: If there is enough clearance between the dryer hood and the journal, you can install cantilever support tube by inserting it through the partially assembled joint and down the journal bore. Leave the tapered end of the tube protruding out of the end cap approximately 7" (178 mm). Lubricate the o-ring (26) and place it into the o-ring groove on the joint body. Make sure the drive lock pin on the end of the cantilever support tube inside the dryer is at the 12 o'clock position. From outside the dryer the pin location can be confirmed by putting the syphon code numbers stamped in the cantilever support tube at the 12 o'clock position. Make sure the split wedges (J) are in the proper position and place the body over the cantilever support tube and install the lockwashers (K) and hex head cap screws (L). Lift the body and cantilever support tube into position

over the studs (20A) on the ring bracket (20) and secure into position with nuts (20B). At this time the hex head cap screws (L) **must** be tightened evenly to 105 ft/lbs (142 Nm) using a torque wrench. Place gasket (8) onto the head (2) and secure it to joint body using the hex nuts (2B).

Option 2: Before putting the support tube (I) inside the dryer remove the split wedges (J) and o-ring (26) and set aside. From inside the dryer, slide the support tube down the journal, split wedge end first. Reinstall the split wedges and o-ring once the support tube is passed through the dryer journal. Allow the end of the support tube to protrude out of the end cap approximately 7" (178 mm). Lubricate the o-ring (26) and place it into the o-ring groove on the joint body (1). Make sure the drive lock pin on the end of the cantilever support tube inside the dryer is in the 12 o'clock position. Position the body over the cantilever support tube and install bolts and lockwashers (K & L). Lift the body and cantilever support tube and position over the studs (20A) on the ring bracket (20) and secure into position with nuts (20B). At this time the hex head cap screws (L) **must** be tightened evenly to 105 ft/lbs (142 Nm) using a torque wrench. Place gasket (8) onto head and secure it to the joint body using the hex nuts (2B).

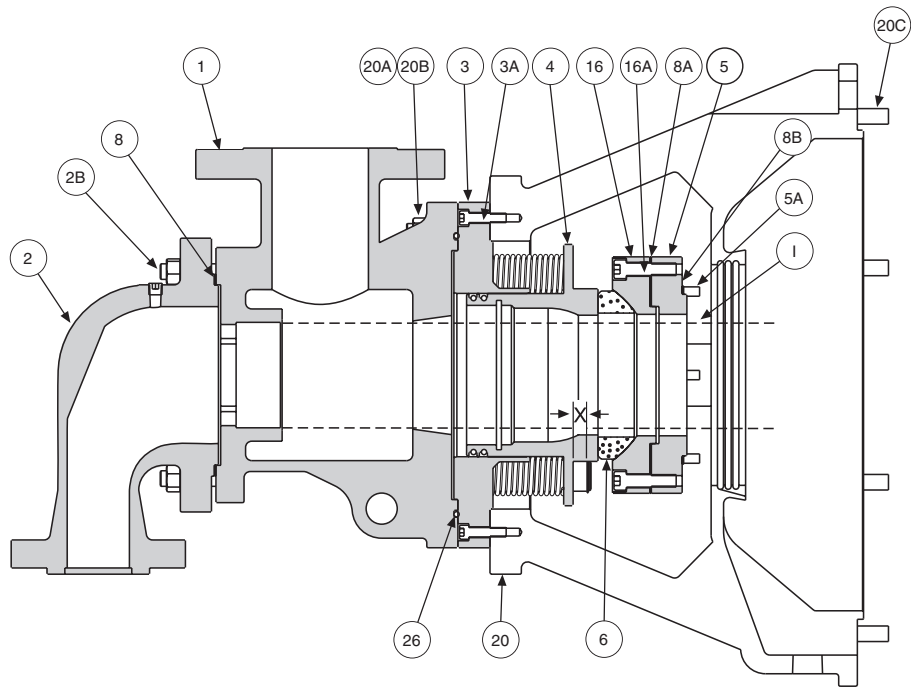

Figure 1

STEP 8.

After either option for the cantilever support tube installation is complete, the rest of the syphon installation may be finished.

Inside the dryer, position the support bracket (E) over the end of the cantilever support tube, remove the pipe clamps (D) and set aside. Sealing the threads with pipe sealer, install the vertical pipe (F) to the horizontal pipe (H) and tighten. Slide the pick-up fitting (A) onto the vertical pipe. Slide the horizontal/vertical pipe down the cantilever support tube until it fits into the support bracket and passes through the o-ring (N). Install the pipe clamps. Center the horizontal pipe in the cantilever support tube and secure pipe with the pipe clamp and nuts provided.

STEP 9.

FINAL BRACKET AND PICK-UP FOOT ADJUSTMENT.

Make sure the support bracket (E) is vertical and the syphon pick-up fitting is at the bottom of the dryer. The pick-up fitting must be pointed into the rotation of the dryer (see Figure 3). Adjust the circular portion of the support bracket so that it is 1/4" (6 mm) back from the end of the support tube. Tighten support bracket clamp bolts (M). Set the pick-up fitting clearance by placing a gauge in the center of the pick-up fitting (contact Kadant Johnson for clearance specification). Tighten the small set screw in the side of the pick-up fitting and double check the clearance. Secure into final position by tightening bolt/nut (B & C). If the desired pick-up fitting clearance can not be obtained, the vertical pipe (F) can be cut off allowing for more adjustment.

STEP 10.

Check all counter weights and make sure they will clear the syphon assembly as the dryer rotates. If necessary, the support bracket can be move away from the dryer head up to 1/4" (6 mm) by loosening the bolts and repositioning the bracket. Check the cantilever support tube for clearance through the journal. The cantilever support tube must have at least 3/16" (5 mm) clearance between its O.D. and the journal I.D.

Specifications and dimensions are for reference only and subject to change. Certified drawings are available on request.

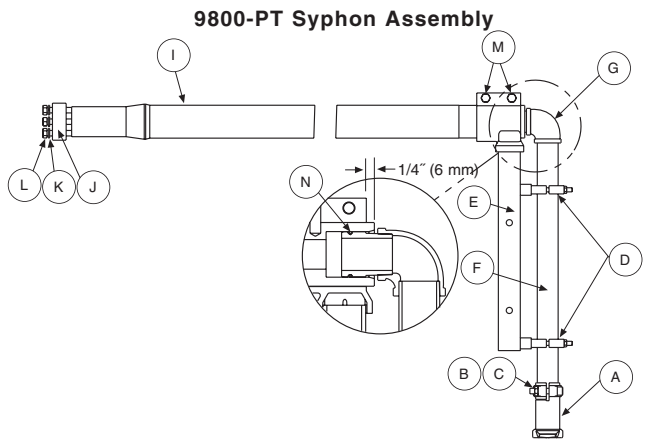

Figure 2

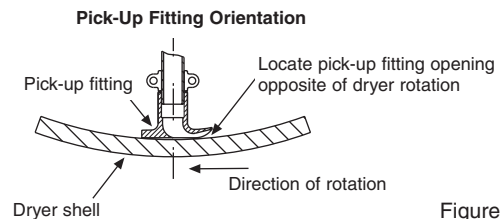

Figure 3

The Kadant Johnson Warranty

Kadant Johnson products are built to a high standard of quality. Performance is what you desire: that is what we provide. Kadant Johnson products are warranted against defects in materials and workmanship for a period of one year after date of shipment. It is expressly understood and agreed that the limit of Kadant Johnson's liability shall, at Kadant Johnson's sole option, be the repair or resupply of a like quantity of non-defective product.

