

Installation Instructions for Type IC Joints – 6000 Series

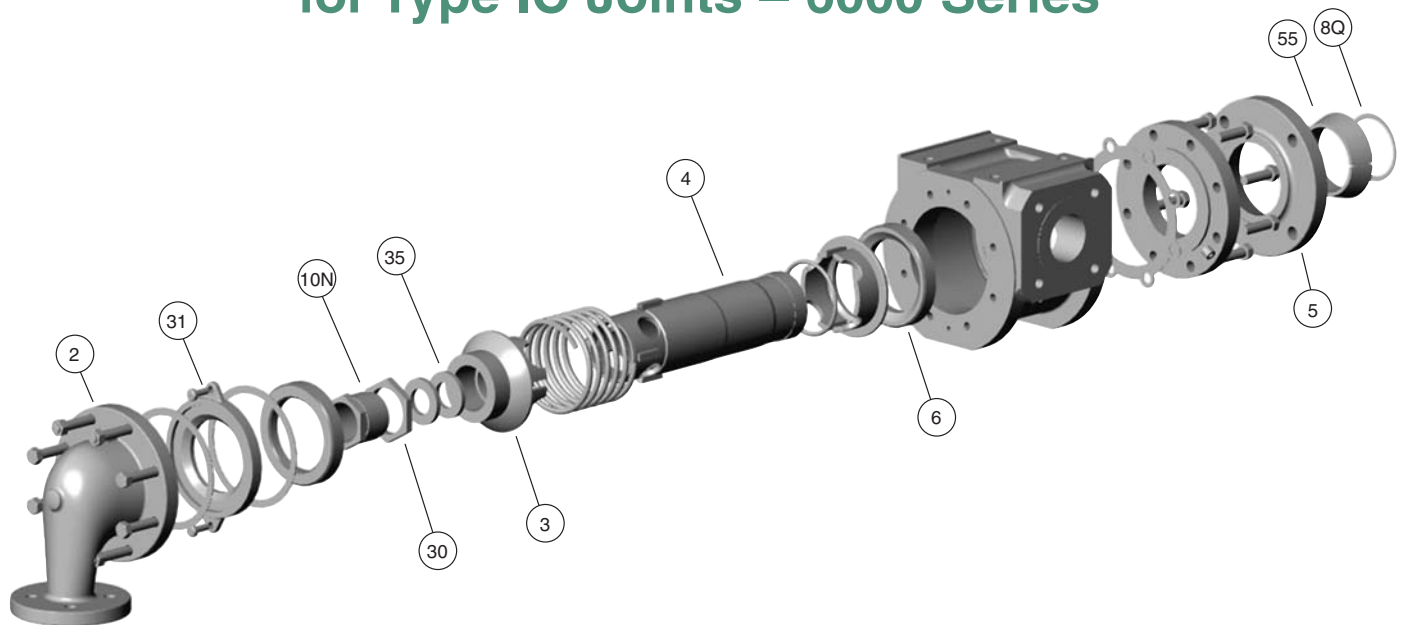

Type 6000NAW-IC

Follow your company's safety procedures whenever working on Kadant Johnson products. Read all of the instructions before proceeding with the installation or repair.

Please refer to the Kadant Johnson assembly drawing for part identification. Assembly drawings are available on request from Kadant Johnson.

Lubricate all fasteners with anti-seize compound. Tighten all fasteners in a star pattern. Torque specifications are listed on the product assembly drawing and are available from Kadant Johnson.

STEP 1.

Check to make sure that all debris has been removed from the piping and roll before installing joint. This will eliminate carbon seal ring scoring and damage to internal joint parts which could cause unnecessary downtime and maintenance.

STEP 2.

Remove the head (2) from the joint leaving the assembly plate (31) attached and remove the packing gland (10N), locknut (30), and packing (35).

IMPORTANT: The inner pipe must be straight, true, and attached within the roll so it rotates without wobbling. This will prevent straining internal joint parts which could cause leakage and carbon seal ring breakage. Make sure the pipe is clean and smooth where it rides in the packing gland.

STEP 3.

Place the copper gasket (8Q) into the journal flange recess where the joint nipple will seat.

STEP 4.

Slide the quick release nipple flange (5) over the joint nipple (4) with the taper facing away from the joint housing.

STEP 5.

Lift the joint and slide it over the syphon pipe protruding from the journal.

CAUTION: Do not allow the joint housing to rest on the syphon pipe as this may bend the pipe.

STEP 6.

Slide the joint toward the journal until the syphon pipe has passed through the thrust collar (3) and the 'Q' nipple (4) is seated against the copper gasket.

STEP 7.

Bolt the housing to bracket, but do not tighten.

STEP 8.

Place the two split tapered wedges (55) into the recess of the nipple (4). Slide the quick release nipple flange over the wedges and secure to the journal flange studs with nuts provided. Tighten evenly. Note that the 'Q' nipple flange will not seat tightly against the face of the journal flange. When tight, there will be approximately 1/8" to 3/16" (3 to 5 mm) space between the two flanges.

STEP 9.

Pull the joint housing away from the journal until it "bottoms out" The total travel will be approximately 3/8" (10 mm). Push the joint towards the journal 1/8" (3 mm), hold securely in this location, and tighten the four mounting bolts. At this time check

alignment since this is critical for proper operation. The nipple must be on the journal centerline and the joint body must be centered around the nipple. Shims may be required.

STEP 10.

Reinstall the packing (35) and packing gland (10N). Apply approximately 30 ft-lbs (41Nm) of torque to the gland and tighten the locknut (30).

NOTE: The thrust collar and gland arrangement will move outward on the pipe as carbon seal wear takes place.

STEP 11.

Replace the joint head (2).

STEP 12.

Connect the joint to piping using Kadant Johnson stainless steel flexible hose of sufficient length to eliminate strains from external piping. When fabricating the piping, use spool pieces in place of the flexible metal hose (ask for spec sheet A97-PS-1615-4-1).

IMPORTANT: Connect the hose as close to the joint as possible. Provide suitable support for the pipe and fittings beyond the hose.

NOTE: Never apply oil or grease to Kadant Johnson joints. The saturated steam, condensate, or liquid passing through it is the only lubrication required for the carbon-graphite parts.

NOTE: Minimize running Kadant Johnson joints dry. Excessive seal wear may occur.

CAUTION

Check the rotary joint regularly to determine carbon seal ring wear using a seal ring indicator. Seal wear indicator tools are available from Kadant Johnson. Refer to your installation drawing for seal ring wear checking procedures. Should the seal ring (6) wear away completely, the metal nipple will wear into the wear plate requiring extensive part replacement.

Dimensions are for reference only and subject to change. Certified drawings are available on request.

The Kadant Johnson Warranty

Kadant Johnson products are built to a high standard of quality. Performance is what you desire: that is what we provide. Kadant Johnson products are warranted against defects in materials and workmanship for a period of one year after date of shipment. It is expressly understood and agreed that the limit of Kadant Johnson's liability shall, at Kadant Johnson's sole option, be the repair or resupply of a like quantity of non-defective product.

KADANT
AN ACCENT ON INNOVATION
www.kadant.com