

# Installation Instructions for Type RX Unions (2" – 3")

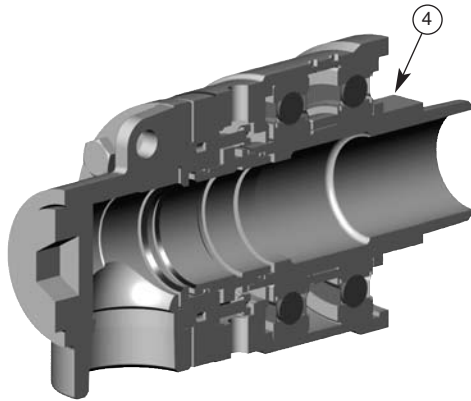

Type RXA

Single Flow

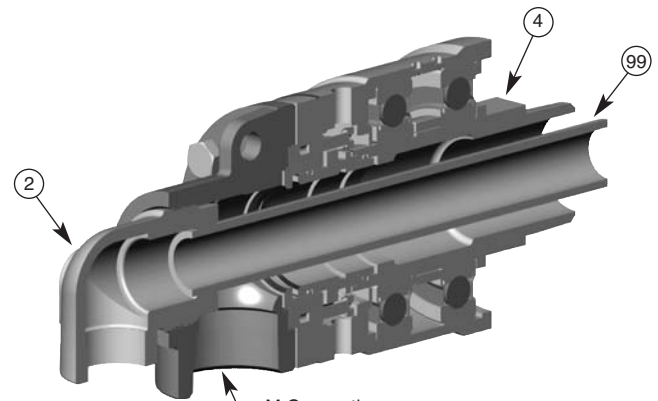

Type RXB2

Dual Flow

**NOTE:** Please follow your company's safety procedures whenever working on Kadant Johnson rotary unions and read all of the instructions completely before proceeding.

Please refer to the assembly drawings supplied with your Kadant Johnson rotary union for part identification. If you have any questions, please contact your Kadant Johnson Representative or Kadant Johnson.

### Single Flow (RXA) No Supply Pipe

Attach in manner described in **Mounting to Journal** given your nipple design.

### Dual Flow (RXB2) Stationary Supply Pipe

First thread the supply pipe (99) into the rotary union elbow (2) and then attach union to the journal.

### Dual Flow (RXB2N) Rotary Supply Pipe

Holding union straight, slide slowly over supply pipe (99) and into elbow (2). Then attach to journal.

### Mounting to Journal

**Threaded Nipple:** Using the required sealant for your nipple, thread the nipple (4) into journal and tighten: Pipe Sealant (Tapered); Gasket (Straight).

**Quick Release Nipple:** Place gasket into journal flange; Place nipple flange and split wedges on 'Q' nipple; Tighten bolts evenly on nipple flange so that space between flanges is even.

**Integral Flanged Nipple:** Place gasket on nipple flange and place on journal with studs extending through nipple flange. Tighten nuts evenly in a star pattern to seal flange surfaces and minimize runout.

*Pay special attention to concentricity. At high speeds the bearings will yield longer, trouble-free service life if runout is kept to a minimum. See Table 1 for speed and maximum runout allowance.*

### Installation Notes

1. Take special care when mounting union over supply pipe as internal seals can be damaged.
2. Supply pipe can be guided to the elbow while looking through the M connection.
3. Attention should be given to length of supply pipe. Excess length can cause flow to be cut off against interior of elbow.
4. If reusing existing elbow (2) with supply pipe attached, fully thread into new union body to ensure supply pipe is properly engaged inside the roll.

### RX Union Speed and Runout Allowances

Size	Maximum Speed For Mounting Configuration (rpm)			Dual Flow With Rotating Supply Pipe	Maximum Runout
	Integral Flange	Tapered Pipe Threads	"Q" Nipple		
2" 2 1/2" 3"	1,000	750	750	750	0.012" (0.30 mm)

Table 1

## Flexible Hose Connection

Given your application, choose either rubber or metal braided hose, with ratings able to sustain the flow media. When connecting the rotary union to the fixed piping the flexible hose should be installed as close to the union as possible, in a relaxed condition, neither stretched or compressed. If you have an unusually long run of hose, it is strongly suggested that you support the hose so as not to overload the bearings. Refer to Table 2 to determine the correct length of flexible hose needed to isolate the Kadant Johnson union from piping stresses.

RECOMMENDED MINIMUM HOSE LENGTHS		
Hose Size	Minimum Length	
3/4"	12"	300 mm
1"	15"	380 mm
1 1/4"	18"	450 mm
1 1/2"	18"	450 mm
2"	21"	530 mm
2 1/2"	24"	610 mm
3"	27"	690 mm

Table 2

## Vent Holes

There are four vent holes in the body of the rotary union. They provide an escape for leakage at the internal seals (which indicate the need for seal replacement) and also prevent penetration of the fluid to the bearings. The rotary union should be oriented such that one of the vent holes is pointing directly downward.

---

### The Kadant Johnson Warranty

Kadant Johnson products are built to a high standard of quality. Performance is what you desire: that is what we provide. Kadant Johnson products are warranted against defects in materials and workmanship for a period of one year after date of shipment. It is expressly understood and agreed that the limit of Kadant Johnson's liability shall, at Kadant Johnson's sole option, be the repair or resupply of a like quantity of non-defective product.

**KADANT**  
AN ACCENT ON INNOVATION  
[www.kadant.com](http://www.kadant.com)