

Installation Instructions for Type RX Rotary Unions (3/8" – 1 1/2")

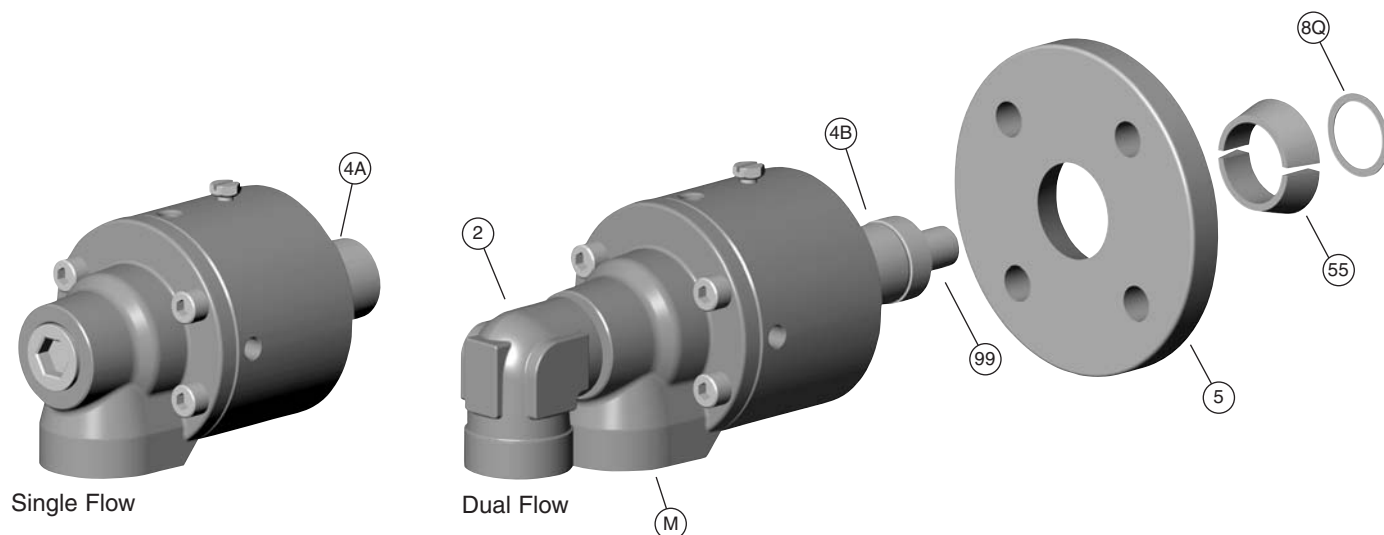

Please follow your company's safety procedures whenever working on Kadant Johnson rotary unions and read all of the instructions completely before proceeding.

Please refer to the engineering drawings of your Kadant Johnson rotary union for part identification. If you have questions, please contact your representative or Kadant Johnson.

Single Flow (RXA) No Supply Pipe

Attach in manner described in **Mounting to Journal** given your rotor design.

Dual Flow (RXB2) Stationary Supply Pipe

First thread the supply pipe (99) into the rotary union elbow (2) and then attach union to the journal.

Dual Flow (RXB2N) Rotary Supply Pipe

Holding union straight, slide slowly over supply pipe (99) and into elbow (2). Then attach to journal.

MOUNTING TO JOURNAL

Threaded Rotor: Using the required sealant for your rotor, thread the rotor (4A) into journal and tighten: Pipe Sealant (Tapered); Gasket (Straight); O-Ring (C.A.M.M.).

Quick Release Rotor: Place copper gasket (8Q) in journal flange recess. Slide the quick release flange (5) over the rotor (4B) with the taper facing away from the union. Place split wedge (55) into the rotor recess,

then slide the quick release flange over it. Position union/flange into journal flange and tighten the fasteners evenly. Note: There will be a 1/8" to 3/16" (3 mm to 5 mm) gap between the journal flange and the quick release flange, make sure the gap is even.

Integral Flanged Rotor: Place gasket on rotor flange and place on journal with studs extending through rotor flange. Tighten nuts evenly in a star pattern to seal flange surfaces and minimize runout.

Pay special attention to concentricity. At high RPM's the bearings will yield longer service life if runout is kept to a minimum.

INSTALLATION NOTES

1. Take special care when mounting union over supply pipe as internal seals can be damaged.
2. Supply pipe can be guided to the elbow while looking through the M connection.
3. Attention should be given to length of supply pipe. Excess length can cause flow to be cut off against interior of elbow.
4. If reusing existing elbow (2) with supply pipe attached, fully thread the elbow into new union body to ensure supply pipe coupling is properly engaged inside the roll.

FLEXIBLE HOSE CONNECTION

Given your application, choose either rubber or metal braided hose, with ratings able to sustain the flow media. When connecting the rotary union to the fixed piping the flexible hose should be installed as close to the union as possible, in a relaxed condition, neither stretched or compressed. If you have an unusually long run of hose, it is strongly suggested that you support the hose so as not to overload the bearings. Refer to Table 1 to determine the correct length of flexible hose needed to isolate the rotary union from piping stresses.

RECOMMENDED MINIMUM HOSE LENGTHS		
Hose Size	Minimum Length	
1/4"	8"	200 mm
3/8"	10"	250 mm
1/2"	10"	250 mm
3/4"	12"	300 mm
1"	15"	380 mm
1 1/4"	18"	450 mm
1 1/2"	18"	450 mm

Table 1

VENT HOLES

There are four vent holes in the body of the rotary union. They provide an escape for leakage at the internal seals which indicate the need for seal replacement. The rotary union should be oriented such that one of the vent holes is pointing directly downward.

Dimensions are for reference only and subject to change. Certified drawings are available on request. Please refer to Kadant Johnson Drawing Number A37640 for torque specifications.

The Kadant Johnson Warranty

Kadant Johnson products are built to a high standard of quality. Performance is what you desire: that is what we provide. Kadant Johnson products are warranted against defects in materials and workmanship for a period of one year after date of shipment. It is expressly understood and agreed that the limit of Kadant Johnson's liability shall, at Kadant Johnson's sole option, be the repair or resupply of a like quantity of non-defective product.

KADANT
AN ACCENT ON INNOVATION
www.kadant.com