

Installation Instructions for Type 2800 and 2950 ELSNARQ Joints (Without An Assembly Plate)

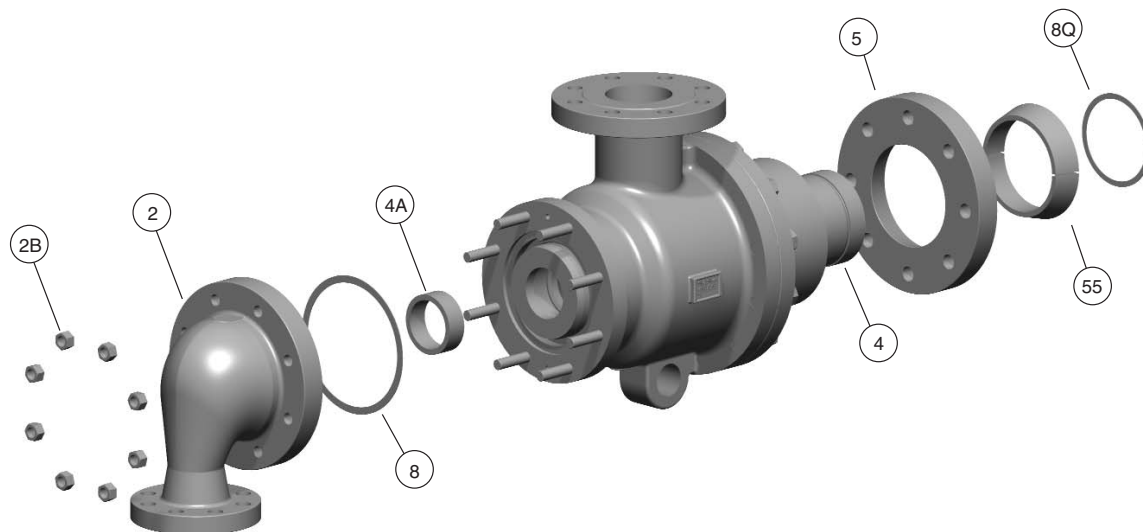

Follow your company's safety procedures whenever working on Kadant Johnson products. Read all of the instructions before proceeding with installation or repair.

Please refer to the Kadant Johnson assembly drawing for part identification. Assembly drawings are available on request from Kadant Johnson.

Lubricate all fasteners with anti-seize compound. Tighten all fasteners in a star pattern. Torque specifications are listed on the product assembly drawing and are available from Kadant Johnson.

STEP 1.

Check to make sure that all debris has been removed from the piping and roll before installing joint. This will eliminate carbon seal ring scoring and damage to internal joint parts which could cause unnecessary downtime and maintenance.

STEP 2.

Remove the hex nuts (2B) and the head (2) from joint. If optional packing gland is used, remove locknut, packing gland, and packing (see Figure 2). Make sure horizontal pipe is clean and smooth where it seals to o-rings (4A) or packing (4A). If o-rings are present, lubricate the pipe so it slides smoothly through o-rings. Lubrication is not necessary with packing.

IMPORTANT: The horizontal pipe must be straight, true, and secured within the roll so it rotates without run out.

STEP 3.

Slide the quick release nipple flange (5) onto the nipple (4) with its taper facing outward. Place the two split taper wedges (55) into the recess of the nipple and slide the quick release nipple flange over the wedges.

STEP 4.

Place a new metal gasket (8Q) into the counterbore of the journal flange.

STEP 5.

Position the joint with quick release flange/nipple assembly (4, 5, and 55) pointed towards the journal flange or roll end. Slide the joint over the horizontal pipe until the pipe passes through the o-rings or packing (4A). Insert the nipple into the journal flange counterbore. Slide the quick release nipple flange (5) over the journal flange studs and secure flange with hex nuts. Tighten hex nuts evenly. The end of the horizontal pipe should extend 3/8" (10 mm) past the end of the nipple or optional packing gland if used. See Figure 2.

Note: The quick release nipple flange (5) will not seat tightly against the face of the journal flange. When tight there will be approximately a 1/8" to 3/16" (3 to 5 mm) space between the flanges. Make sure this gap is equal around the circumference of the flanges.

STEP 6.

When a packing gland is used, reinstall the packing, packing gland, and locknut. Tighten packing gland to 30 ft-lb (41 Nm), then tighten locknut.

STEP 7.

Reinstall head (2) with new gasket (8). Secure the head using hex nuts (2B).

STEP 8.

Connect piping to joint using Kadant Johnson flexible metal hose. Two hoses should be installed in the inlet and two in the outlet piping. See Flexible Hose Piping Recommendations, IS-Flexible Hose. The hose(s) should be long enough to minimize any piping loads on the rotary joint. The joint must

be free to move outward to compensate for seal ring wear. See recommended flexible metal hose length chart in Table 1.

NOTE: Connect the hose directly to the rotary joint. Minimize the use of fittings and pipe between the rotary joint and flexible hose. This increased weight can affect the performance of the rotary joint. Provide suitable support for the pipe and fitting beyond the hose.

STEP 9.

Install anti-rotation rod in the anti-rotation rod hole. See Table 2 for recommended rod size. No more than two joints should be joined with one anti-rotation rod. Secure the rod to the rod hole of one joint and let it float in the second joint. This will absorb the torque generated by the joint, and prevent premature hose failure by reducing stresses.

Never apply oil or grease to this series of Kadant Johnson joints. The saturated steam, condensate, or liquid passing through is the only lubrication required for the carbon-graphite parts.

Minimize running Kadant Johnson joints dry. Excessive seal wear may occur.

PROCEDURE FOR DETERMINING SEAL RING WEAR

Check the rotary joint regularly to determine seal ring wear. As shown in Figure 1, the shoulder on the nipple will move outward as seal ring wear takes place. Should the seal ring (6) wear away completely, the metal nipple (4) can contact the joint body (1) and the wear plate (16), eventually wearing through it. This will result in a significant leak and create a hazardous condition. Metal to metal contact of these parts may require replacement of the entire joint instead of just the seal ring.

STEP 1.

Determine the location of a shoulder that is machined into the shaft of the rotary joint nipple (see Figure 1).

STEP 2.

As the seal ring begins to wear, the joint moves away from cylinder. Reference Table 3 for maximum seal ring wear.

STEP 3.

When the body moves out from the shoulder to meet the dimension found in Table 3, replace the seal ring.

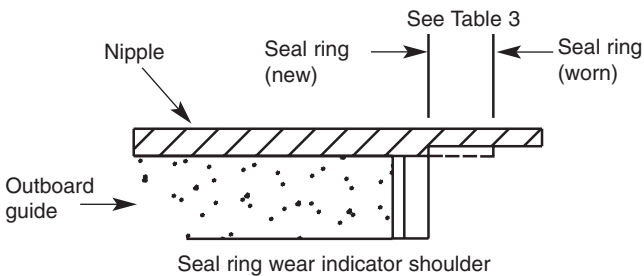

Figure 1.

TABLE 1		
RECOMMENDED MINIMUM HOSE LENGTHS		
Hose Diameter	Minimum Length	
1-1/2"	18"	450 mm
2"	21"	530 mm
2-1/2"	24"	610 mm
3"	27"	690 mm
4"	28"	710 mm

TABLE 2		
RECOMMENDED SIZES FOR ANTI-ROTATION RODS		
Joint Size	Model Number	Round 1018 Steel Bar
4"	2800	1-1/4"
5"	2950	1-1/2"

TABLE 3		
MAXIMUM SEAL RING WEAR		
Joint Size	Seal Wear	
4"	9/16"	14 mm
5"	9/16"	14 mm

Dimensions and specifications are for reference only and subject to change. Certified drawings are available on request. Please refer to Kadant Johnson Drawing Number A37640 for torque specifications.

Packing and O-Ring Configurations
Figure 2.

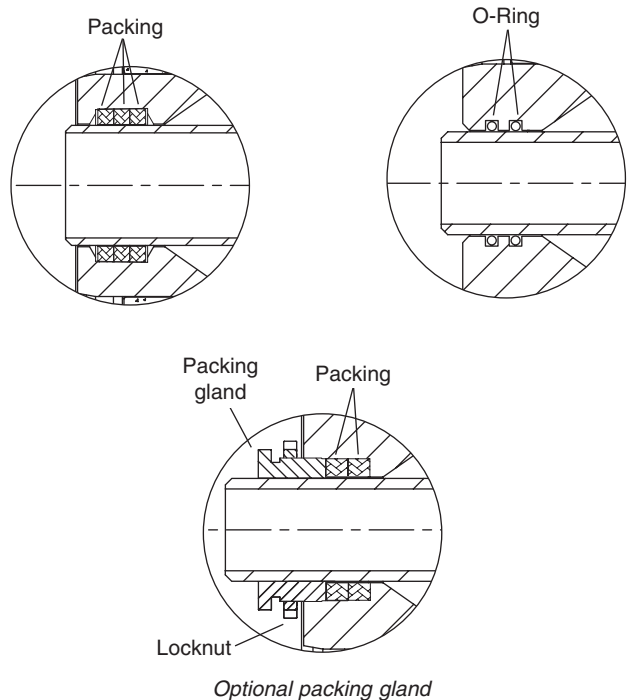

The Kadant Johnson Warranty

Kadant Johnson products are built to a high standard of quality. Performance is what you desire: that is what we provide. Kadant Johnson products are warranted against defects in materials and workmanship for a period of one year after date of shipment. It is expressly understood and agreed that the limit of Kadant Johnson's liability shall, at Kadant Johnson's sole option, be the repair or resupply of a like quantity of non-defective product.

KADANT
AN ACCENT ON INNOVATION
www.kadant.com