

Installation Instructions for Type IC Joints 2000 Series With Ring Bracket Mounting

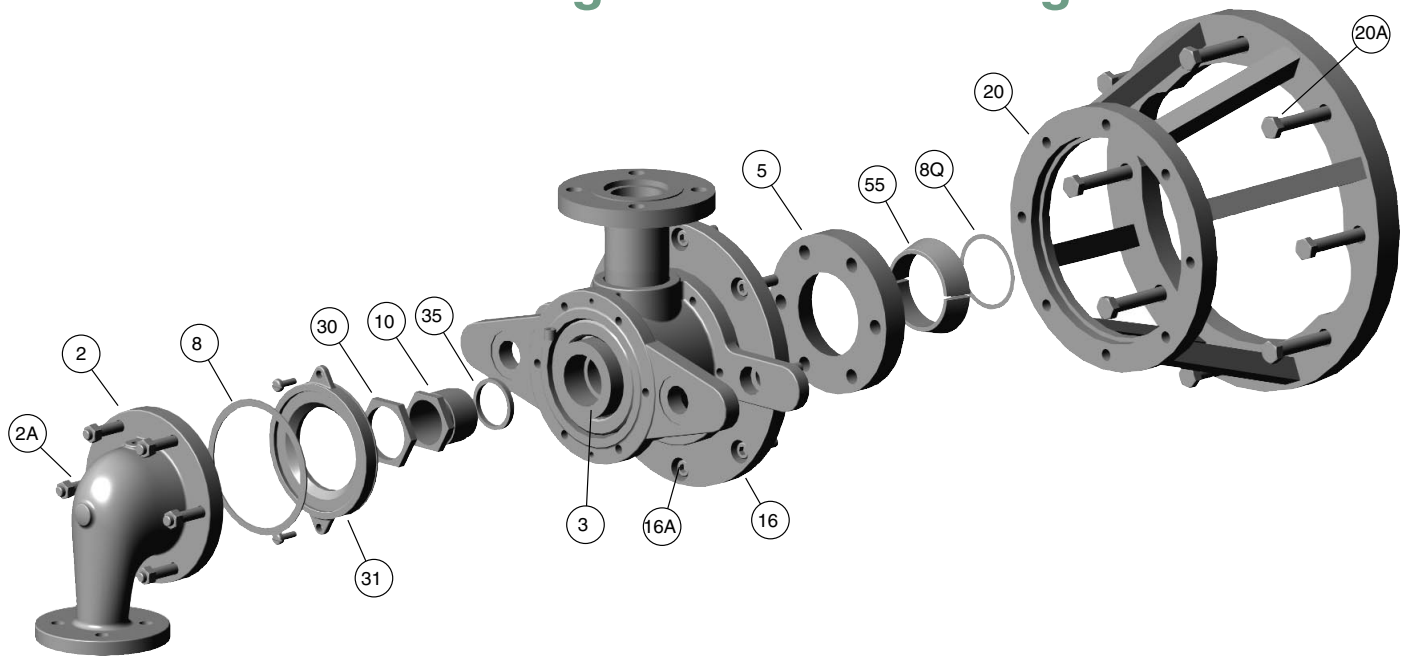

Type 2700LNARQ-IC

NOTE: Please follow your company's safety procedures whenever working on Kadant Johnson Rotary Joints and read all of the instructions completely before proceeding.

Please refer to the assembly drawings supplied with your Kadant Johnson Rotary Joint for part identification. If you have any further questions, please contact your Representative or Kadant Johnson.

STEP 1.

Shut off steam and condensate valves. Remove all of the existing equipment down to the bearing cover. If the journal flange is to be replaced, remove it and install a new one with new gasket (and o-ring if equipped) at this time.

STEP 2.

Make sure the horizontal pipe is the proper length. Please refer to the "H" dimension on the rotary joint drawing.

STEP 3.

Install the ring bracket (20), making sure it is in the correct position. Secure it into position using the proper length bolts (20A). Tighten the bolts to the specified torque using a star pattern.

STEP 4.

Place a new copper gasket (8Q) into the counterbore of the journal flange.

STEP 5.

Loosen and remove the head bolts (2A). Remove the head (2) and head gasket (8) and set aside.

STEP 6.

Loosen the packing gland lock nut (30). Remove the packing gland (10) and packing (35). Set the gland and packing material aside, they will be installed later.

STEP 7.

Slide the quick release nipple flange (5) over the end of the nipple (4) with its tapered bore facing the end of the nipple.

STEP 8.

Place two tapered split wedges (55) into the recessed portion on the nipple and slide the quick release nipple flange over them. Hold the quick release nipple flange into position with a C clip. See Chart A. Other methods, such as a large radiator hose clamp, maybe used in place of the C clip.

STEP 9.

Rotate the nipple so that the key and keyway in the nipple can be observed through the inlet connection. Note: This area will need to be checked over during the final inspection.

STEP 10.

Carefully lift the rotary joint and position it over the horizontal pipe. Do not allow the weight of the joint may bend it. Pass the horizontal pipe through the nipple and through the thrust collar (3). Do this while placing the end of the nipple into the counterbore of the journal flange. Align the holes in the quick release nipple flange with studs in the journal flange and continue to move the joint into position.

STEP 11.

Place the proper amount of nuts over the studs on the journal flange to secure the quick release nipple flange. Tighten the nuts to approximately 70 ft-lb using star pattern. The use of a torque wrench in this area is difficult because of the close proximity of other components, please make sure the nuts are tight.

Note: When the quick release journal flange is tight there will be a 1/8" to 3/16" gap between its face and the face of the journal flange. Make sure this gap is even around the circumference of the quick release flange to prevent the nipple from being drawn off center.

STEP 12.

Place bolts (16A) through the wear plate (16) and secure joint assembly to the ring bracket. Tighten the bolts using a star pattern using the proper torque.

STEP 13.

Re-install the packing that was previously removed. Make sure the ends of the packing are staggered to prevent leaks. Re-install the packing gland and lock nut. Tighten the packing gland to 30 ft-lb and secure into position using the lock nut.

CHECKING THE JOINT ALIGNMENT AND FINAL INSPECTION

STEP 14.

Make sure the nipple is centered in the wear plate. Make sure the thrust collar (3) is centered in the assembly plate (31). Measure the gap between these parts by using a piece of 1/8" welding rod bent at a 90 degree angle. If the joint is off center, alignment can be adjusted by slightly loosening the ring bracket and moving it. The joint should be aligned within .060" ± of the centerline of the roll. Once properly aligned, dowel pin the ring bracket to the bearing cover. Dowel pinning the ring bracket will ensure proper joint alignment when future repairs are made.

Make sure there is 1/8" to 1/4" gap between the heel of the key in the nipple and the bottom of the keyway in the nipple body (Please see Figure 1). This inspection is done through the inlet connection. The gap should be visible by placing a screw driver between the spring (7) and the nipple body and twisting it so that the bottom of the key and keyway become visible.

If these specifications can not be achieved please contact your Representative or Kadant Johnson.

STEP 15

Re-install the head gasket and head. Tighten the head bolts to their proper torque using star pattern.

This completes the installation and the joint is ready for the piping to be attached. Attach the flex hoses to the joint inlet and outlet connections first. This will minimize the amount of weight on the joint caused by excess pipe fittings. The hoses must be installed straight and relaxed, neither compressed or stretched.

If you converting existing joints to 2000 series IC Joints, you will need to replace the nipple, wear plate, and thrust collar. Please see repair instructions R-2000IC with Ring Bracket.

Dimensions are for reference only and subject to change. Certified drawings are available on request. Please refer to Kadant Johnson Drawing Number A37640 for torque specifications.

Retaining Clip		
Joint Size	Part ID	Description
2"	16272374	Retaining clip for 2550
2-1/2"	16293341	Retaining clip for 2600
3"	16324859	Retaining clip for 2700
3-1/2"	16340227	Retaining clip for 2750

Chart A

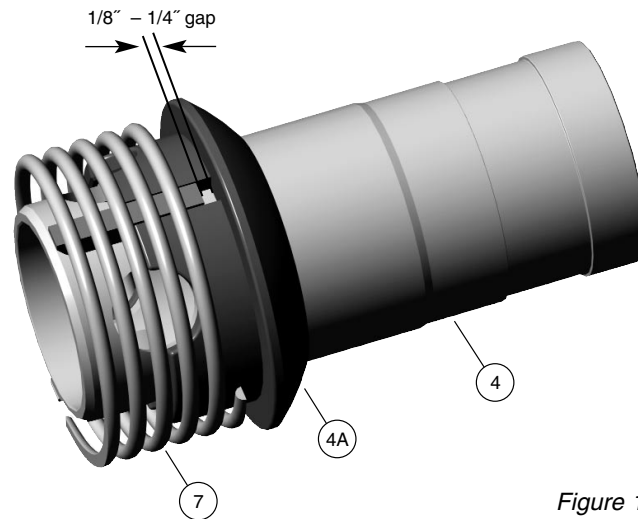

Figure 1

The Kadant Johnson Warranty

Kadant Johnson products are built to a high standard of quality. Performance is what you desire: that is what we provide. Kadant Johnson products are warranted against defects in materials and workmanship for a period of one year after date of shipment. It is expressly understood and agreed that the limit of Kadant Johnson's liability shall, at Kadant Johnson's sole option, be the repair or resupply of a like quantity of non-defective product.



www.kadantjohnson.com