

# PTX Joint & Syphon System

## For high performance dryers

**KADANT**  
AN ACCENT ON INNOVATION

Designed for superior  
performance and  
reliability.

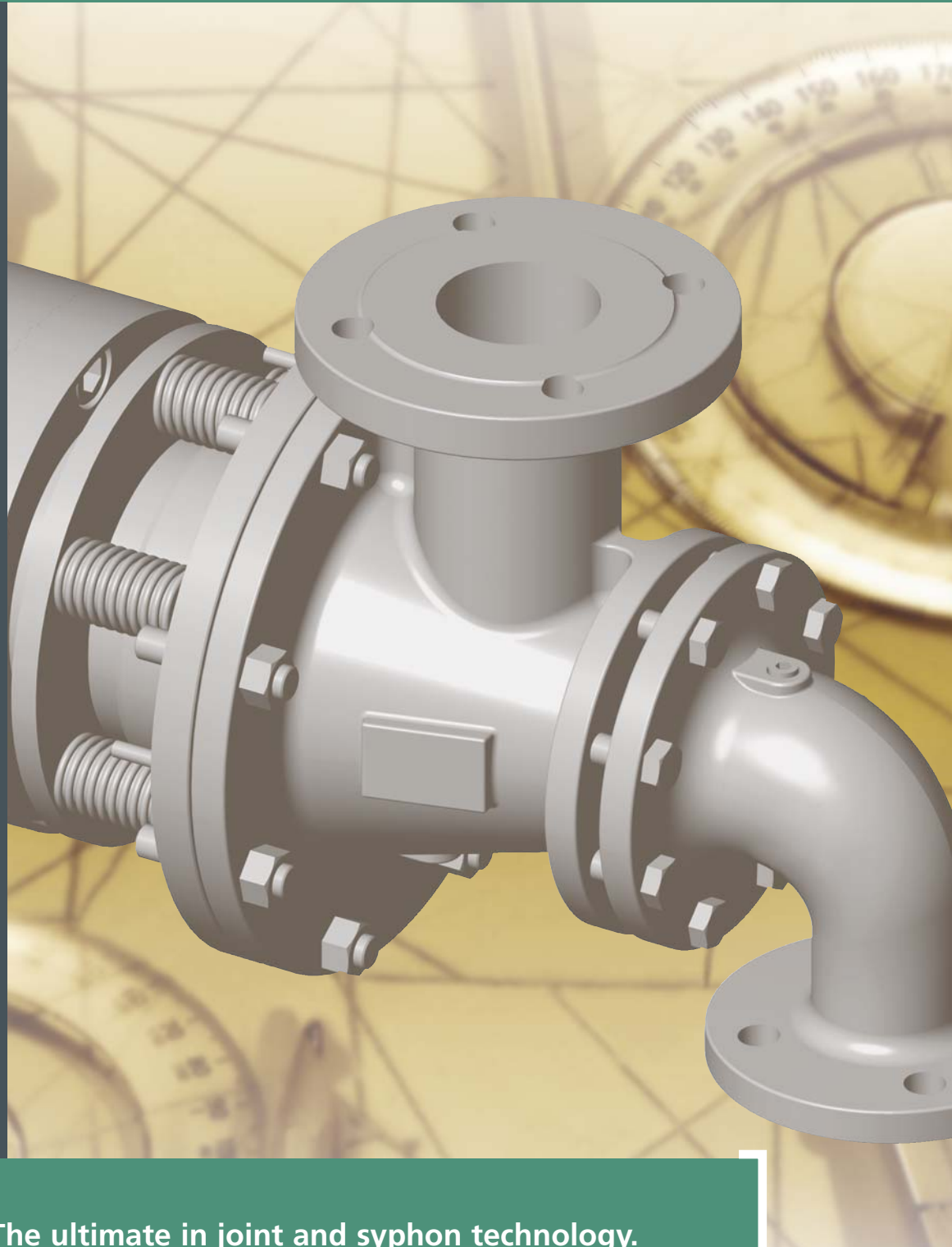
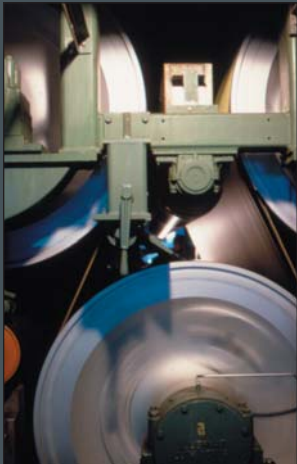

The ultimate in joint and syphon technology.

# High Performance Drying

Kadant Johnson's PTX steam joint and cantilever stationary syphon are the ultimate in joint and syphon technology for paper machine dryers. This modern system allows you to operate your steam and condensate system over a wide range of conditions, with flexibility and reliability.

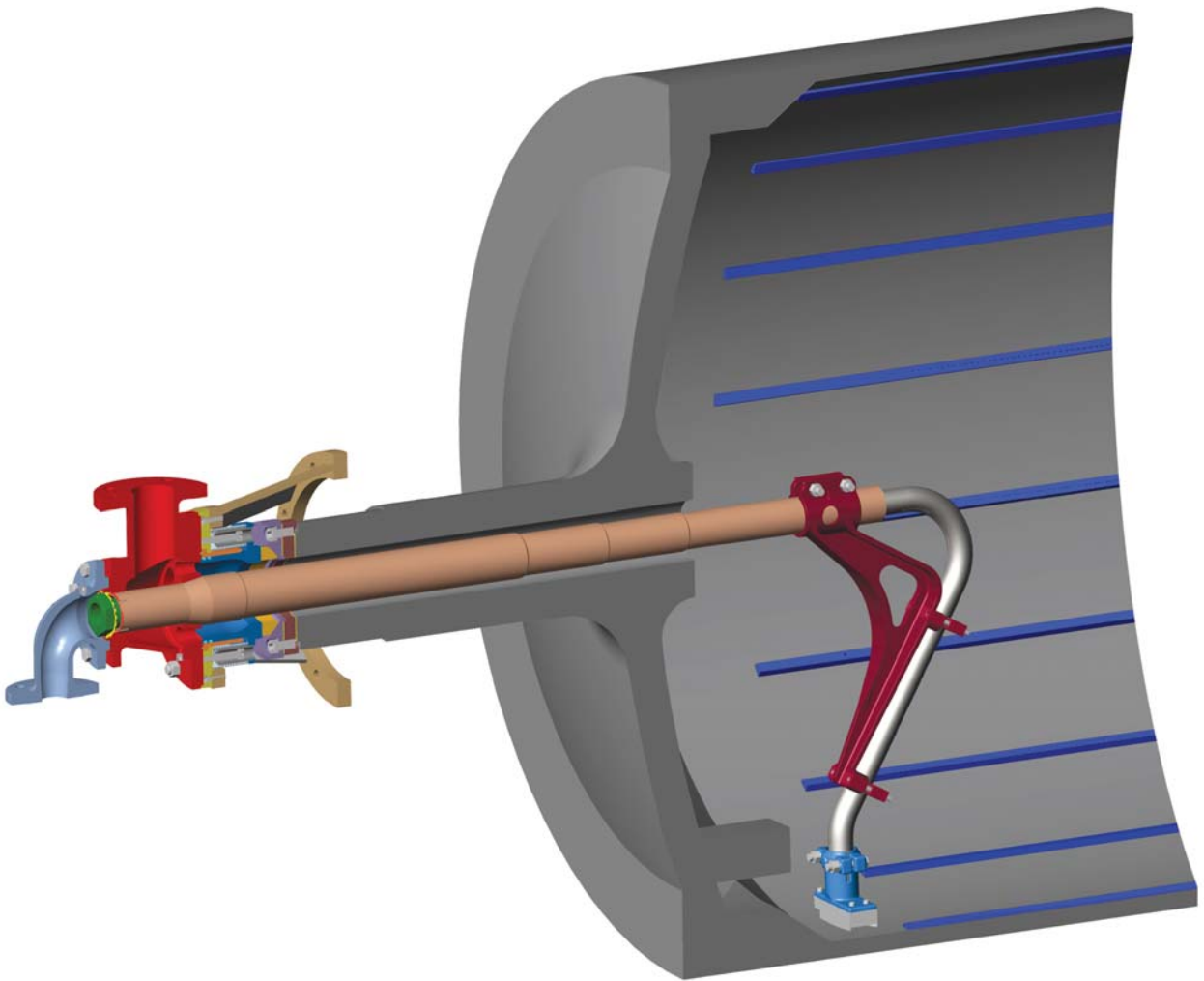

## Why the PTX steam joint is better

- ▶ Lightweight design for easy installation and maintenance
- ▶ Accommodates thermal expansion up to 20 mm
- ▶ Balanced seal design handles run-out and angular misalignment
- ▶ Large flow area for low pressure drop
- ▶ No shims required for set-up

## Why the PTX stationary syphon is better

- ▶ Low operating pressure differentials for efficient operation at high speeds
- ▶ Rigid mounting for greatly improved high speed reliability
- ▶ Controlled condensate levels for more efficient and consistent heat transfer
- ▶ Custom-engineered to avoid vibration harmonics

# PTX Joints

# Syphon System

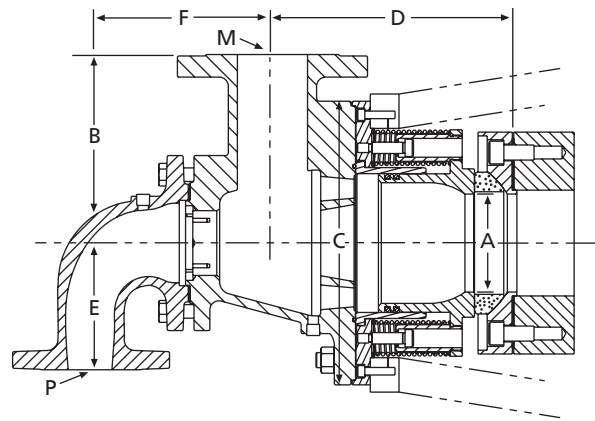

PTX Joint

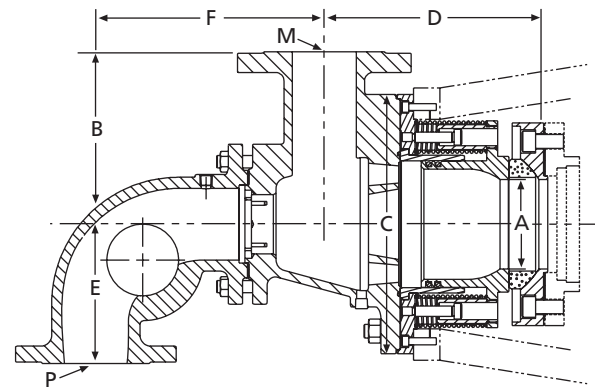

PTX Joint with sight glass head

Model	Size	M	P	A	B	C	D	E	F	Units
9750	3½"	3	2	4.00	7.81	11.75	9.69	5.25	7.50	inches
		DN 80	DN 50	100	200	300	245	135	190	mm
9800	4"	4	2½	5.25	9.06	13.88	11.19	5.75	8.50	inches
		DN 100	DN 65	135	230	350	285	145	215	mm
9750*	3½"	3	2	4.00	7.81	11.75	9.69	6.30	10.35	inches
		DN 80	DN 50	100	200	300	245	160	265	mm
9800*	4"	4	2½	5.25	9.06	13.88	11.19	6.30	11.06	inches
		DN 100	DN 65	135	230	350	285	160	280	mm

\*With sight glass head.

Dimensions are for reference only and subject to change.

## Specifications

Pressure:	160 psig (11 bar)
Temperature:	400°F (204°C)
Speed:	8000 fpm (2500 mpm)

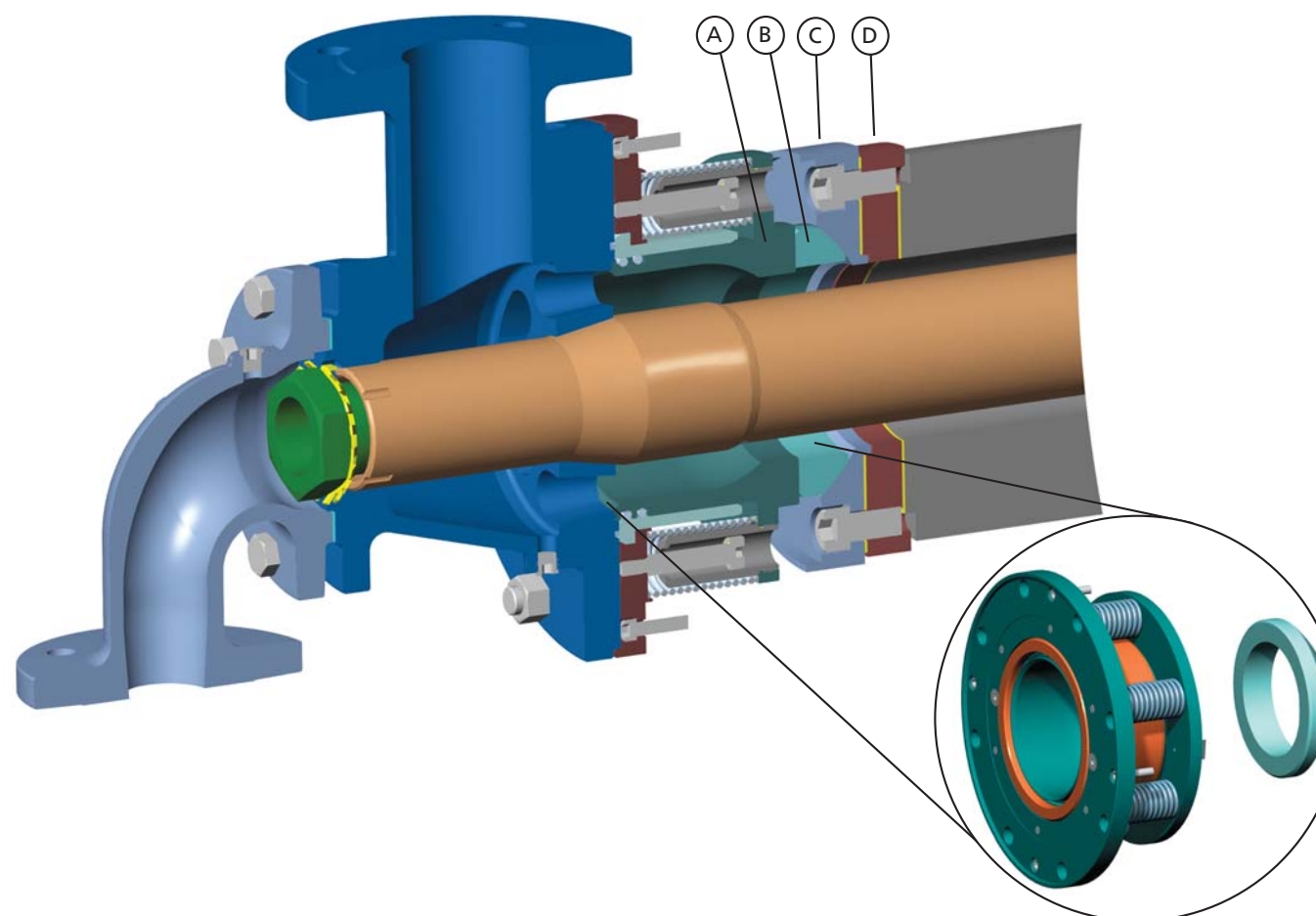
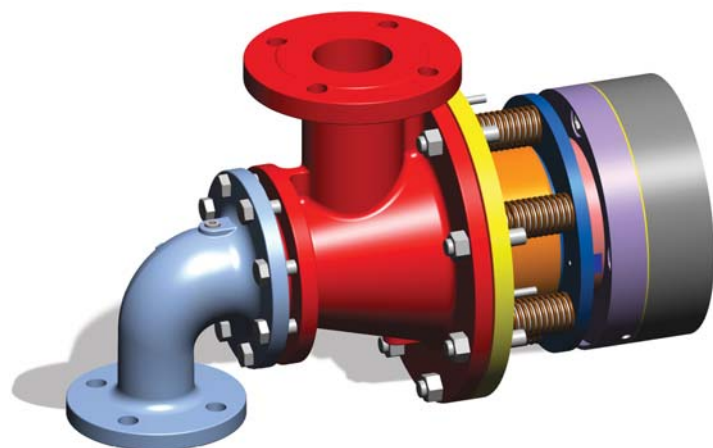

The seal package provides quick seal ring changes, minimizing machine downtime.

## A unique configuration for superior performance

The PTX rotary steam joint is designed for high performance drying. The new design can handle high pressures, high speeds, and misalignment. It can also accommodate thermal expansion of the dryer journal – even when used on the front side of paper machines that have CARB® bearings.

The PTX design uses a spring-loaded piston (A) to apply pressure on the seal ring (B) to keep it securely seated against a spherical seal plate (C). The seal plate is attached to the journal or filler flange (D). The seal plate rotates while the piston remains stationary. The seal ring is free-floating to accommodate angular and offset misalignment.

## Easy to install, even easier to maintain

The robust seal package and lightweight assembly reduce installation time to a fraction of the time it takes to install, set-up, and shim other steam joints. In addition to the ease of installation, the PTX balanced seal design maintains low seal loading for less seal ring wear and longer intervals between seal ring replacements.

## Stationary syphons designed for effective condensate removal

The Kadant Johnson PTX rotary joint is designed specifically for the cantilever stationary syphon. The rigid PTX ring bracket supports the syphon through a horizontal tube that passes through the dryer journal. The tube is held in the joint with a taper lock and a specially designed hollow bolt. The syphon is positioned in the dryer and locked to the horizontal support tube. Following maintenance on the steam joint, the Kadant Johnson syphon can be put back into position without entering the dryer.

The support tube (A) provides the rigidity needed to resist the impact of condensate on the syphon shoe and the vortices that result.

This rigidity is further enhanced by the vertical support (B). This one-piece support strengthens and stiffens the vertical syphon pipe, to minimize its deflection and vibration. Decreased vibration allows the syphon shoe clearance to be accurately set, resulting in increased drying capacity and consistency of operation.

The syphon shoe (C) has a stainless steel clamp and a Teflon tip to further reduce the potential for dryer damage. It has a narrow profile to reduce flow resistance, loading stresses, and vibrations. The double-cut, double-bolt clamp and corrosion resistant material ensure long term performance.

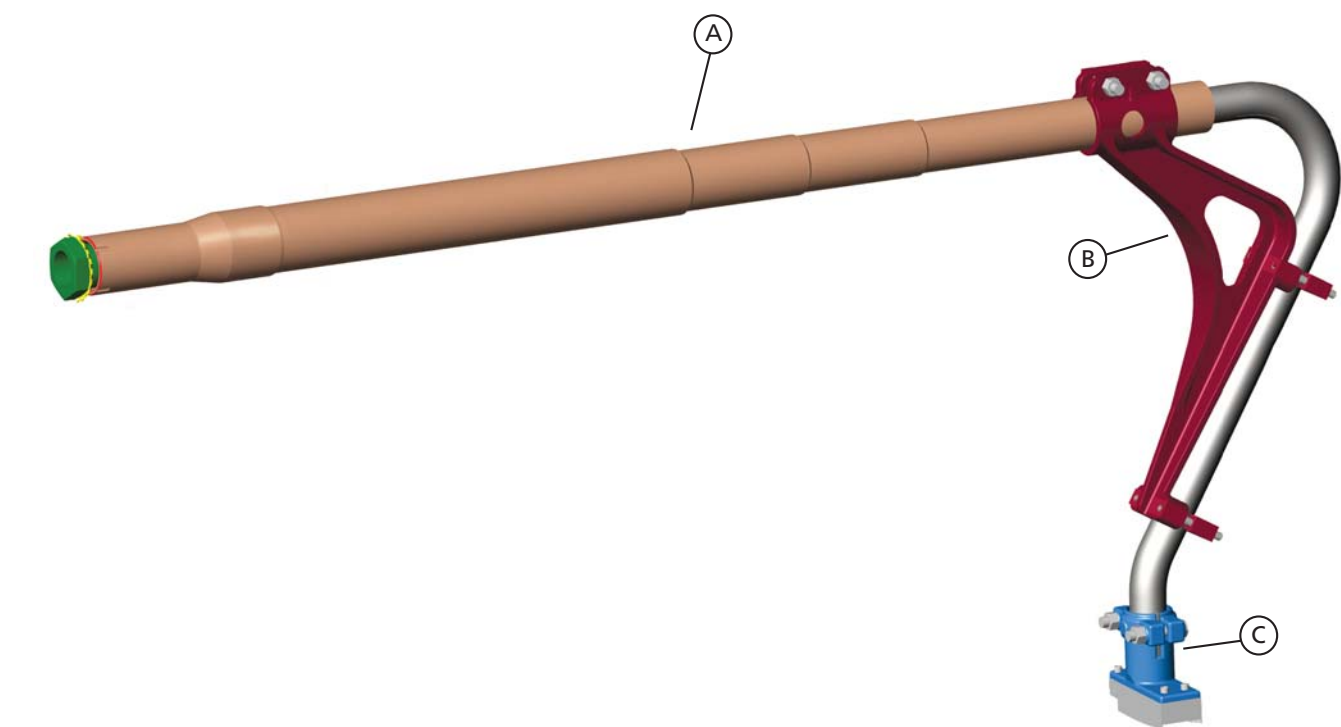

A cantilever syphon's critical components.

# Drive Your Dryer Section to Higher Performance...Without Risk

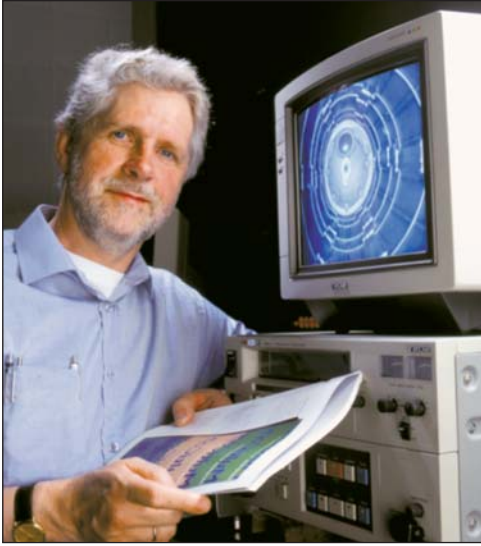

*Looking inside the dryer to optimize drying efficiency.*

Whether you are looking to boost drying efficiency or optimize your steam and condensate system, Kadant Johnson R&D opens the door to explore your drying potential.

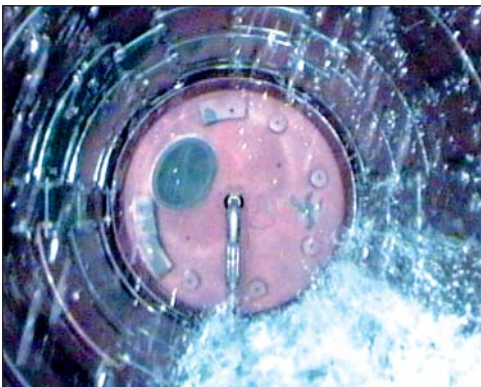
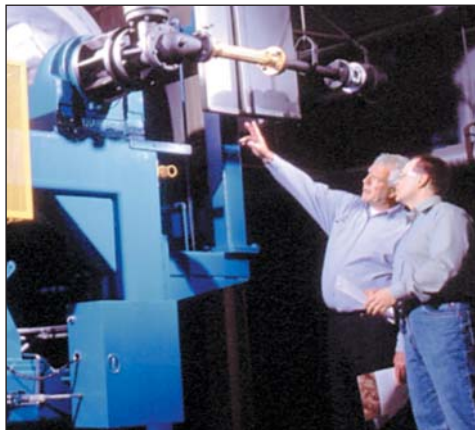

*Real-time view inside the dryer cylinder.*

Papermakers from around the world "test drive" their latest ideas at the Kadant Johnson R&D Center, simulating operating conditions, testing steam and condensate options for the future of their paper machines. The Kadant Johnson R&D Center is unique in allowing a real-time view inside the dryer cylinders.

The Research Center can select and demonstrate the right combination of rotary joints, syphons, and associated components to meet your specific requirements.

**KADANT**  
AN ACCENT ON INNOVATION

Kadant is a leading global supplier of products and services that improve productivity and quality in paper production and other process industries. For the nearest location and contact, visit our Website.

[www.kadant.com](http://www.kadant.com)

Contact us:

KADANT JOHNSON INC.  
805 Wood Street  
Three Rivers, MI 49093 USA

Tel: +1-269-278-1715  
Fax: +1-269-279-5980  
Email: [info@kadant.com](mailto:info@kadant.com)

PTX-3004 05/2009  
replaces PTX-3003  
©2009 Kadant Inc.