

for the most efficient
dryer section
operation

DRYER MANAGEMENT SYSTEM



In the past, managing your dryer section for high performance required operators to be dryer section, steam and control system experts. With the new Dryer Management System™ control software from Kadant Johnson, all steam system set points are automatically and continuously adjusted to create a stable and efficient dryer section operation.

The Dryer Management System (DMS™) control software can be linked directly to the DCS or to an independent dryer drainage controller. Steam system set points are continuously adjusted to keep up with operating changes on the machine. Proper relationships between the various set points allows the dryer section to operate with improved energy efficiency, with fewer breaks, and with a wider range of control.

With the Kadant Dryer Management System, you can take complete control of your dryer section and expect:

- Improved machine efficiency
- Fast sheet moisture control
- Reduced sheet breaks
- Elimination of dryer flooding
- Consistent draw control
- Reduced grade change time
- Reduced tail threading time
- Reduced motive steam use
- Reduced wet-end dryer picking and sheet cockle
- Elimination of steam venting under all conditions
- Wider range of operation
- Rapid start-up following shutdowns
- Consistent dryer section control

The system also provides automatic start-up and shutdown control. This relieves the operator from being tied to the steam system controls and provides consistent control at the fastest rate possible. The system also provides on-line monitoring of exiting press moisture and drying efficiency, providing operators with troubleshooting tools to help fine-tune the dryer section performance by identifying the effect of furnish changes, refining and freeness changes, and press fabric life.

KADANT
JOHNSON

AN ACCENT ON INNOVATION

The Kadant Johnson Dryer Management System™ control software is designed around four modules. Each module provides a unique view of the dryer operation to assist the operator with running the machine.

1. Supervisory Control Module

The heart of the Kadant Johnson Dryer Management System is the Supervisory Control Module. It receives information on the operating conditions (grade, speed, moisture, etc.), computes the pressure curves to meet the current drying requirements to keep the steam system in balance and maintain the MD moisture profile. It then returns the corresponding steam pressure set points. These pressure curves reflect the unique features of the steam system, the machine configuration and the operating requirements. Anti-flooding logic, grade change logic, thermocompressor anti-choke logic, differential pressure adjustment based on syphon curves, automatic system start-up and shutdown and sheet break turndown are incorporated into this module. The Supervisory Control Module includes a graphic interface for the dryer system control, trend analysis and remote system monitoring.

2. Remote Interface Module

The Remote Interface Module provides an operator interface station at the reel panel to control the entire system. Using a simple push-button panel, the drying capacity of the entire steam system can be adjusted upward or downward, while keeping the steam system in balance. This module is particularly useful during sheet breaks, tail threading, grade changes, and emergency stops.

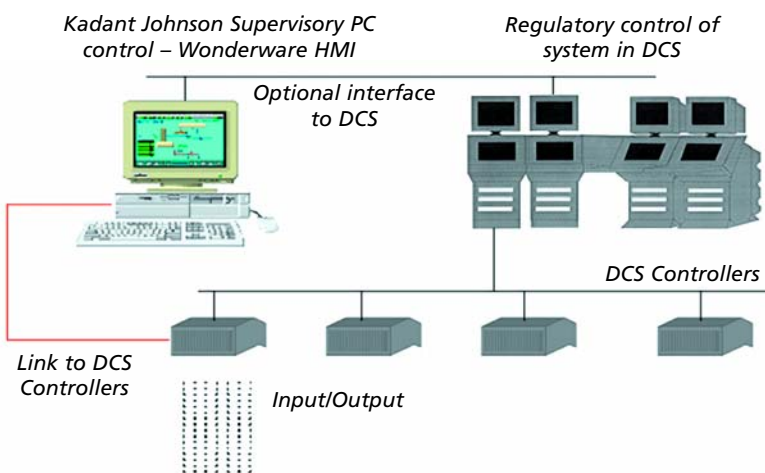

3. Energy Management Module

The Energy Management Module provides a real-time, on-line indication of the exiting press moisture content. Flow meters measure the steam supply and condenser flow rates. This on-line press moisture indicator is useful for troubleshooting machine operation — particularly when frequent grade changes are made. Energy consumption and drying rate are also monitored and trended to show dryer section performance and operating efficiency.

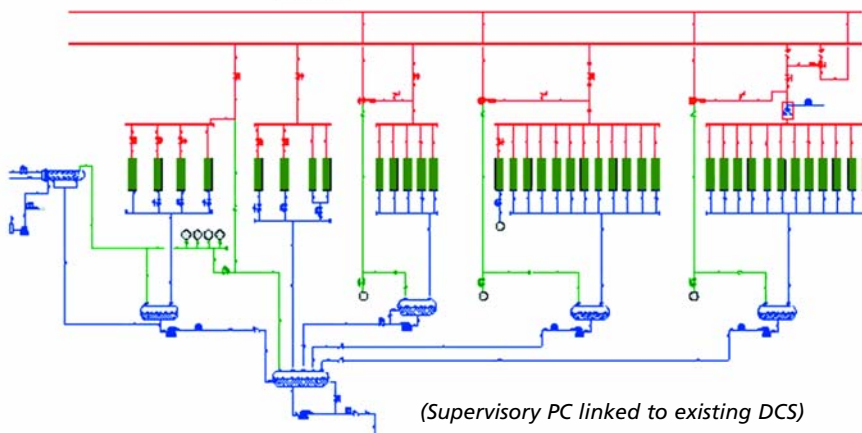

4. Valve Condition Monitoring Module

The Valve Condition Monitoring Module monitors all steam system valves that are equipped with “smart” positioners. Control valve condition is a key to long-term steam system efficiency and reliability. With the Valve Condition Monitoring Module, problems or inefficiencies caused by poor valve operation are detected early, to allow for planned maintenance. The control module is ideal for a system rebuild where new valves and positioners are part of the rebuild project. Kadant Johnson Valve Condition Monitoring software and Fisher Asset Management software are available with this module.