

Cantilever Stationary Syphons

Reliable Condensate Removal

Applications

With more than 14,000 cantilever stationary syphons sold, Kadant Johnson is the preferred supplier and global leader in stationary syphon technology. Our cantilever stationary syphons are designed for use on paper machine dryer sections running up to 2,000 mpm (6,500 fpm) producing paperboard, writing papers, newsprint, and other grades.

Features

- ▶ Stainless steel clamp pad with Teflon shoe
- ▶ Narrow profile with low drag
- ▶ Large syphon tip opening
- ▶ Double-cut, double-bolt clamp secures syphon shoe in place

Benefits

- ▶ Smooth condensate flow into syphon pipe
- ▶ Optimal heat transfer with adjustable syphon clearance
- ▶ Syphon adjustment for precise placement of pick-up shoe
- ▶ Long performance life with corrosion-resistance materials

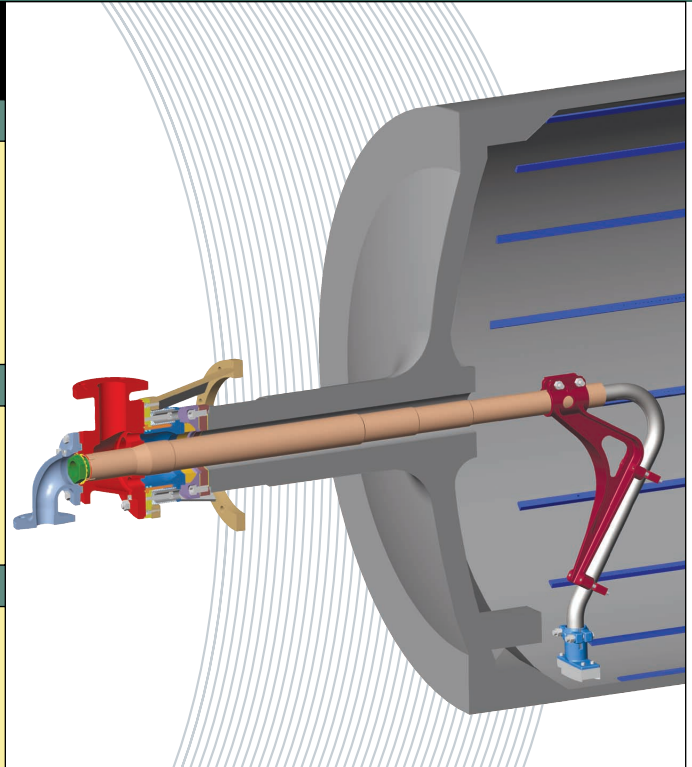

Overcoming traditional high-speed syphon limitations

Rotary syphons require high differential steam pressures to evacuate condensate from high-speed paper machine dryers. Stationary syphons are preferred for these applications, because the differential pressure requirement remains quite low. This reduces blow through steam and improves dryer operating efficiency.

High speeds, however, can create mechanical problems for stationary syphons. All cantilever stationary syphons are mounted and supported from outside the dryer cylinder. Because the stationary syphon remains fixed in place, it must be able to withstand the impact of the condensate that is rotating with the dryer. Stationary syphons with low stiffness will deflect, vibrate, and eventually fail.

The Kadant Johnson cantilever stationary syphon is designed to provide both improved operating efficiency and mechanical reliability.

The cantilever stationary syphon features axial adjustment of the vertical support to allow for fine-tuning the location of the syphon shoe to ensure the correct location inside the dryer. The horizontal support tube can easily slide into the journal bore and be locked into position. A robust hollow bolt secures the support tube in place, eliminating the potential for small fastener failures.

Designed for difficult applications

The Kadant Johnson PTX rotary joint is designed specifically for the cantilever stationary syphon. This joint rigidly supports the horizontal tube that passes through the dryer journal. The tube is held in this joint with a taper lock and a specially designed hollow bolt. The syphon is positioned in the dryer and locked to the horizontal support tube with a single-piece vertical support bracket.

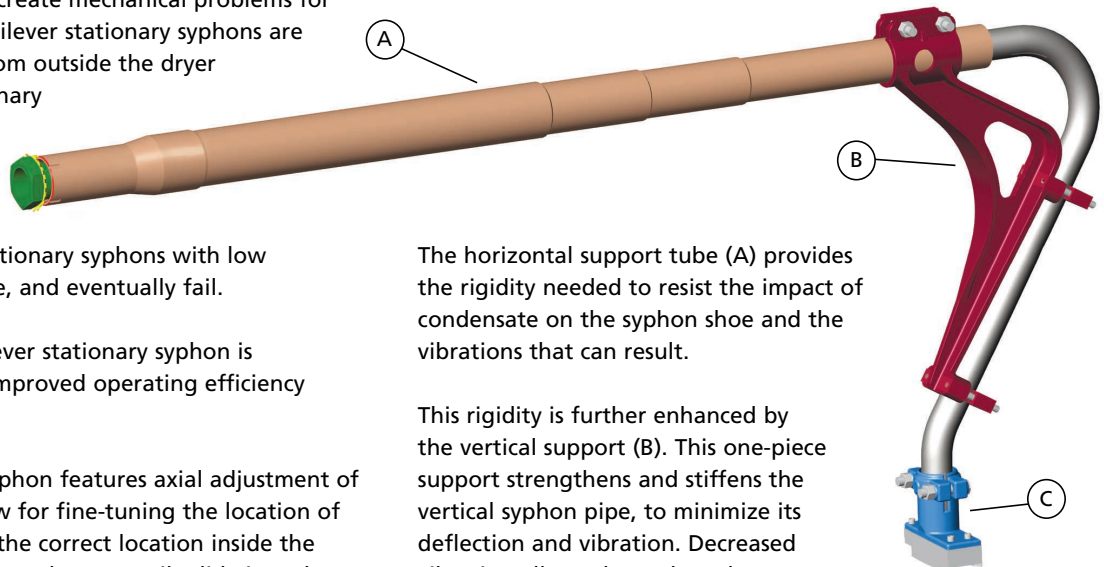

The horizontal support tube (A) provides the rigidity needed to resist the impact of condensate on the syphon shoe and the vibrations that can result.

This rigidity is further enhanced by the vertical support (B). This one-piece support strengthens and stiffens the vertical syphon pipe, to minimize its deflection and vibration. Decreased vibration allows the syphon shoe clearance to be reliably maintained, resulting in increased drying capacity and consistency of operation.

CANTILEVER STATIONARY SYPHONS

The syphon shoe (C) has a stainless steel clamp and a Teflon tip to reduce the potential for dryer damage. It has a narrow profile to reduce flow resistance, loading stresses, and vibrations. The double-cut, double-bolt clamp and corrosion-resistant material ensure long term performance.

Wide range of applications

With its rigid, stable stationary syphon design, the cantilever syphon consistently operates at low differential pressures with no speed limitations. That makes it particularly suited to applications ranging from low speeds to the highest machine speeds in the paper industry.

Optimum syphon sizing: Kadant Johnson's exclusive approach

For peak operating effectiveness, the dryer drainage system must be properly sized and matched with the syphon size and type. Selecting and sizing the syphon and system components

require critical review of operating conditions (e.g. differential pressure, operating pressure, speed, and condensing rates) for the entire range of grades produced. Changes in paper grades, basis weight, or other machine conditions can alter the dryer performance and efficiency.

Using Kadant Johnson's proprietary software programs, coupled with decades of experience, we can evaluate the performance and efficiency of alternative syphon systems, and design a system to meet the requirements of even the most demanding applications.

OPERATING DIFFERENTIAL PRESSURE

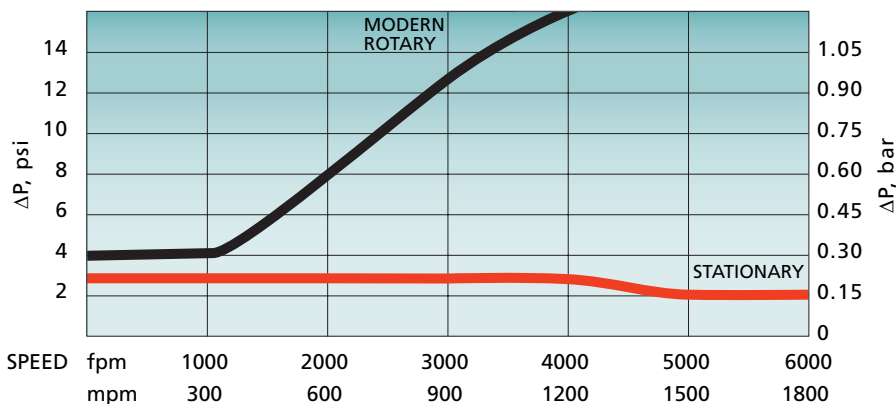

FLOOD RECOVERY DIFFERENTIAL PRESSURE

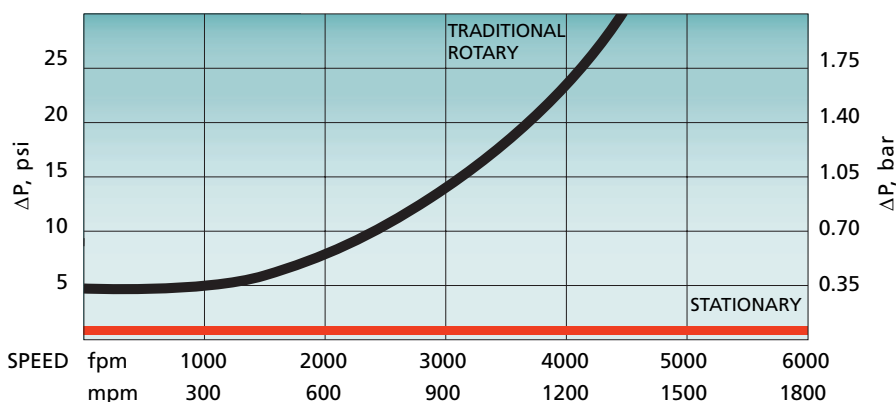

KADANT
JOHNSON

AN ACCENT ON INNOVATION

Kadant Johnson is a leading provider of rotary joints, rotary unions, and precision unions for efficient fluid handling in a range of industries.

www.kadantjohnson.com

Contact us:

KADANT JOHNSON
805 Wood Street
Three Rivers, MI 49093 USA

Tel: +1-269-278-1715
Fax: +1-269-279-5980
Email: info@kadantjohnson.com